

1 PERSONAL PROTECTIVE EQUIPMENT

INTRODUCTION

Personal protective equipment (PPE) is something all construction workers have in common.

PPE is designed to protect against safety and/or health hazards. Hard hats, safety glasses, and safety boots, for instance, are designed to prevent or reduce the severity of injury if an accident occurs.

Other PPE, such as hearing and respiratory protection, is designed to prevent illnesses and unwanted health effects.

It is important to remember that PPE only provides protection. It reduces the risk but does not eliminate the hazard.

This chapter will enable PPE users to

- assess hazards and select a suitable control method
- locate and interpret legislation related to PPE
- effectively use and maintain PPE.

Legal Requirements

While common to all trades, PPE varies according to individual, job, and site conditions.

Legal requirements for personal protective equipment also vary and the appropriate sections of the construction regulation (O. Reg. 213/91) under the *Occupational Health and Safety Act* should be consulted.

The *Occupational Health and Safety Act* makes employers and supervisors responsible for ensuring that required PPE is worn. This does not mean that the employer must provide PPE but only ensure that it is provided by someone.

Workers, meanwhile, have a duty under the Act to wear or use PPE required by the employer. This addresses situations where the regulations may not require PPE but the employer has set additional health and safety standards, such as mandatory eye protection.

The construction regulation (O. Reg. 213/91) broadly requires that such protective clothing, equipment, or devices be worn "as are necessary to protect the worker against the hazards to which the worker may be exposed." It also requires that the worker be trained in the use and care of this equipment.

Control Strategies

Personal protective equipment should be the last resort in defence. Better alternatives lie in engineering controls that eliminate as much of the risk as possible. Engineering controls fall into five categories:

- substitution
- alternative work methods
- isolation
- enclosure
- ventilation.

Substitution

This control substitutes a less toxic chemical that can do the same job. A common example is the substitution of calcium silicate or fibreglass insulation for asbestos insulation. Substitution is an effective control as long as the substitute is less hazardous.

Alternative Work Methods

This simply means doing the job in a way which is less hazardous. For example, brushing or rolling paint produces much lower vapour levels than spray painting. Similarly, wet removal of asbestos releases up to 100 times less dust than dry removal. The change should be checked to ensure that it is safer.

Isolation

Isolation isolates the worker from the hazard. In a quarry, for example, the operator of a crusher can be isolated from dust by a filtered, air-conditioned cab.

Enclosure

A substance or procedure may be enclosed to contain toxic emissions. It may be as simple as putting a lid on an open solvent tank or enclosing asbestos removal projects with polyethylene sheeting (Figure 1). Enclosures have also been built around compressors to reduce the noise level. Enclosures must not restrict access when maintenance is required.

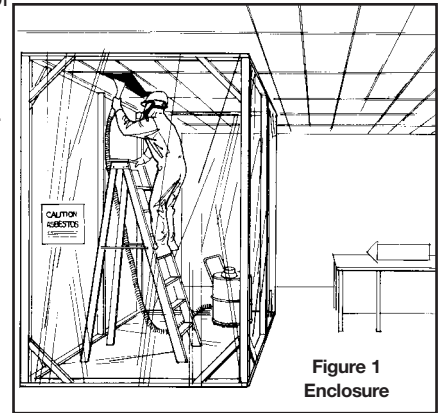

Figure 1 Enclosure

Ventilation

A common engineering control is to dilute the contaminant in the air by using general ventilation. Local ventilation is better because it removes the contaminant. General ventilation may employ fans to move large volumes of air and increase air exchange. This is not suitable, however, for highly toxic materials.

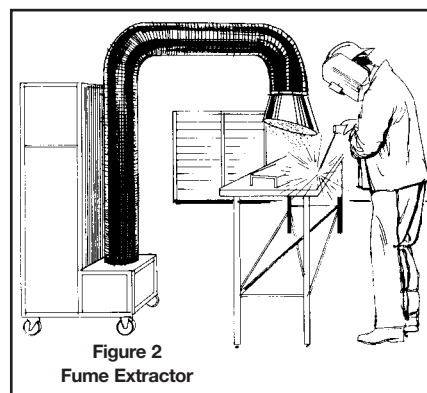

Figure 2 Fume Extractor

Local ventilation captures and removes contaminants at their source. At a shop bench, a fume hood can be constructed to remove dusts and fumes. On sites, portable fume extractors (Figure 2) can be used.

Remember: many filtering systems can only remove fumes—not gases or vapours.

Personal Protective Equipment

When it is not possible to apply any of the five engineering controls, personal protective equipment may be the last resort.

Regulations often refer to Canadian Standards Association (CSA) or other equipment standards as a convenient way to identify equipment which meets requirements and is acceptable. CSA-certified equipment can be identified by the CSA logo (Figure 3). For instance, there are CSA standards for

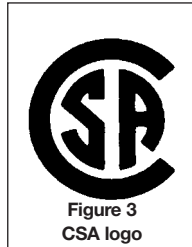

- Head Protection - CSAZ94.1M1992
- Eye Protection - CSAZ94.3-99
- Foot Protection - CSAZ195-M1992

For respiratory protection, National Institute for Occupational Safety and Health (NIOSH) standards and approvals are usually referenced throughout North America.

For life jackets, Transport Canada certification is the standard reference.

EYE PROTECTION

With the permission of the Canadian Standards Association, some information in this chapter is reproduced from CSA Standard CAN/CSA-Z94.3-99, Industrial Eye and Face Protectors, which is copyrighted by Canadian Standards Association, 178 Rexdale Boulevard, Toronto, Ontario M9W 1R3. While use of this material has been authorized, CSA shall not be responsible for the manner in which the information is presented, nor for any interpretations thereof.

Introduction

Eye protection is not the total answer to preventing eye injuries. Education regarding proper tools, work procedures, hazard awareness, and the limitations of eye protection is also very important. Like any other manufactured product, eye protection has material, engineering, and design limitations. But proper eye protection, selected to match the specific construction hazard, combined with safe work procedures, can help to minimize the number and severity of eye injuries.

When we consider that one out of every two construction workers may suffer a serious eye injury during their career, the importance of wearing proper eye protection cannot be over-emphasized. In the hazardous environment of the construction industry, wearing proper eye protection should be considered a labour-management policy, not a matter of individual preference.

Classes of Eye Protectors

Before outlining the type(s) of eye protectors recommended for a particular work hazard, it is necessary to explain the various types of eye protectors available. Eye protectors are designed to provide protection against three types of hazards — impact, splash, and radiation (visible and invisible light rays) — and, for purposes of this manual, are grouped into seven classifications based on the CSA Standard Z94.3-99, *Industrial Eye and Face Protectors*.

The seven basic classes of eye protectors are: spectacles, goggles, welding helmets, welding hand shields, hoods, face shields, and respirator facepieces.

Class 1 – Spectacles (Figure 1)

CSA Standard Z94.3-99 requires that Class 1 spectacles incorporate side protection. Most side shields are permanently attached to the eyewear, but some may be detachable.

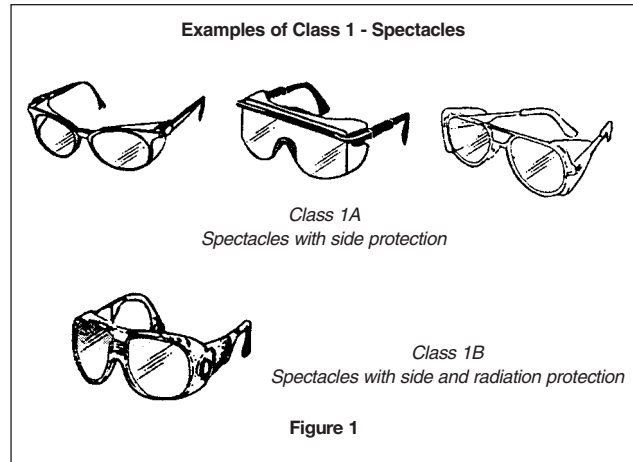

Class 2 – Goggles

There are two types of goggles — eyecup and cover. Both must meet the CSA Z94.3-99 Standard.

Eyecup goggles (Figure 2) completely cover the eye socket to give all-round protection. They have adjustable or elasticized headbands and are equipped with ventilation ports to allow passage of air and prevent fogging. Some have direct ventilation ports which prevent the direct passage of large particles, but do not exclude dust or liquids. Others have indirect ventilation ports which prevent the passage of particles, dust, and liquids. There are also models available with an adjustable chain bridge.

Figure 2 – Eyecup Goggles

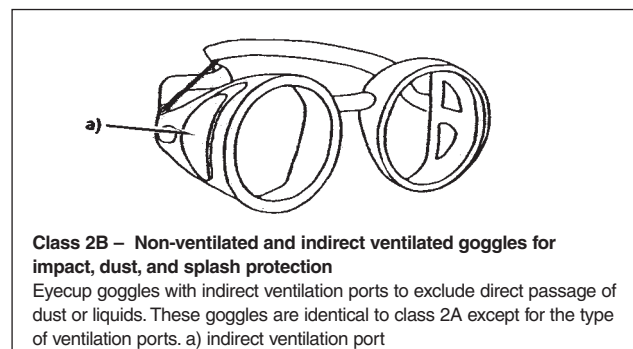
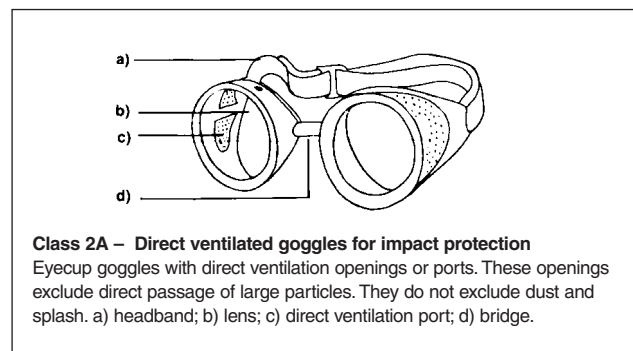

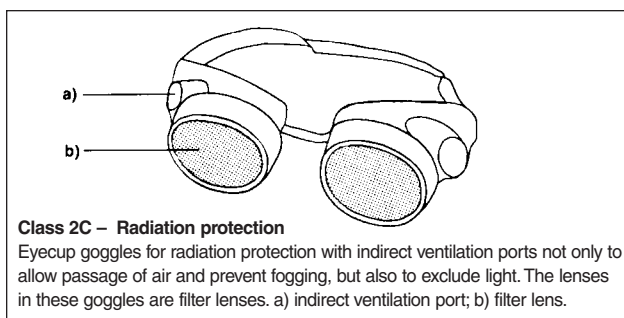

Class 2C – Radiation protection

Eyecup goggles for radiation protection with indirect ventilation ports not only to allow passage of air and prevent fogging, but also to exclude light. The lenses in these goggles are filter lenses. a) indirect ventilation port; b) filter lens.

Cover goggles (Figure 3) are designed to be worn over spectacles. They have adjustable or elasticized headbands and are equipped with direct or indirect ventilation ports to allow passage of air and prevent fogging.

Figure 3 – Cover Goggles

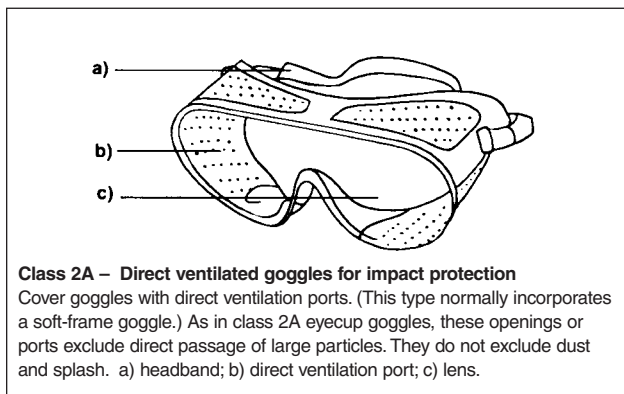

Class 2A – Direct ventilated goggles for impact protection

Cover goggles with direct ventilation ports. (This type normally incorporates a soft-frame goggle.) As in class 2A eyecup goggles, these openings or ports exclude direct passage of large particles. They do not exclude dust and splash. a) headband; b) direct ventilation port; c) lens.

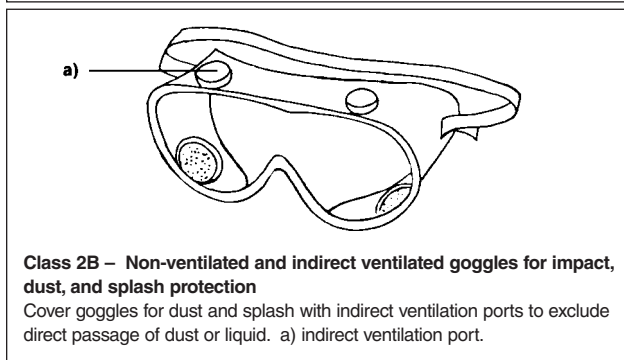

Class 2B – Non-ventilated and indirect ventilated goggles for impact, dust, and splash protection

Cover goggles for dust and splash with indirect ventilation ports to exclude direct passage of dust or liquid. a) indirect ventilation port.

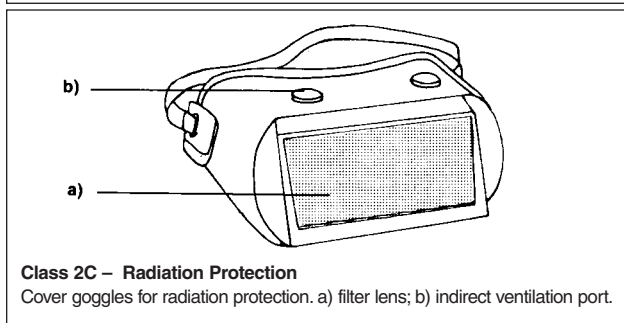

Class 2C – Radiation Protection

Cover goggles for radiation protection. a) filter lens; b) indirect ventilation port.

Class 3 – Welding Helmets (Figure 4)

This class provides radiation and impact protection for face and eyes. There are two types of welding helmets available — the stationary plate helmet and the lift-front or flip-up plate helmet. There are also special models incorporating earmuff sound arrestors and air purification systems. Special magnifying lens plates manufactured to fixed powers are available for workers requiring corrective lenses.

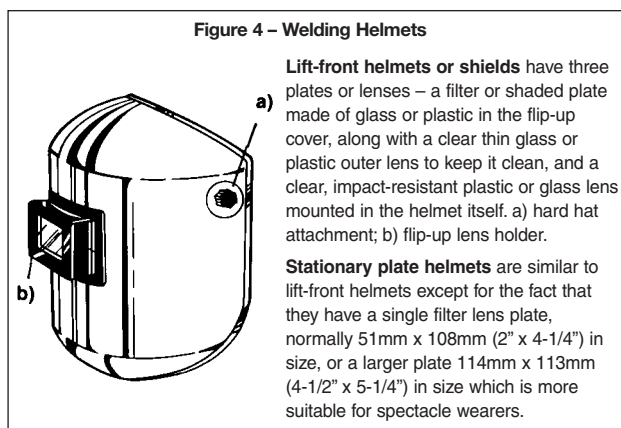

Figure 4 – Welding Helmets

Lift-front helmets or shields have three plates or lenses – a filter or shaded plate made of glass or plastic in the flip-up cover, along with a clear thin glass or plastic outer lens to keep it clean, and a clear, impact-resistant plastic or glass lens mounted in the helmet itself. a) hard hat attachment; b) flip-up lens holder.

Stationary plate helmets are similar to lift-front helmets except for the fact that they have a single filter lens plate, normally 51mm x 108mm (2" x 4-1/4") in size, or a larger plate 114mm x 113mm (4-1/2" x 5-1/4") in size which is more suitable for spectacle wearers.

The filter or shaded plate is the radiation barrier. Arc welding produces both visible light intensity and invisible ultraviolet and infra-red radiation. These ultraviolet rays are the same type of invisible rays that cause skin burning and eye damage from overexposure to the sun. However, ultraviolet rays from arc welding are considerably more severe because of the closeness of the eyes to the arc and lack of atmospheric protection. In arc welding, therefore, it is necessary to use a filter plate of the proper lens shade number to act as a barrier to these dangerous light rays and to reduce them to the required safe degree of intensity. For proper welding shade numbers, see Table 2, page 46.

In addition to common green filters, many special filters are also available. Some improve visibility by reducing yellow or red flare; others make the colour judgment of temperature easier. A special gold coating on the filter lens provides additional protection by reflecting radiation.

Class 4 – Welding Hand Shields (Figure 5)

Welding hand shields are designed to give radiation and impact protection for the face and eyes.

NOTE: With welding helmets and hand shields, the user is continually lifting and lowering the visor. To protect the eyes when the visor is lifted, Class 1 spectacles should be worn underneath.

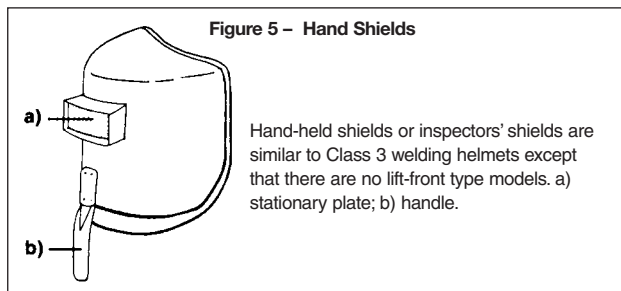

Figure 5 – Hand Shields

Hand-held shields or inspectors' shields are similar to Class 3 welding helmets except that there are no lift-front type models. a) stationary plate; b) handle.

Class 5 – Hoods (Figure 6)

Non-rigid helmets or hoods come with impact-resistant windows usually made of plastic. An air-supply system may also be incorporated. Hoods may be made of non-rigid material for use in confined spaces and of collapsible construction for convenience in carrying and storing.

Hood types include

- 5A with impact-resistant window
- 5B for dust, splash, and abrasive materials protection
- 5C with radiation protection
- 5D for high-heat applications.

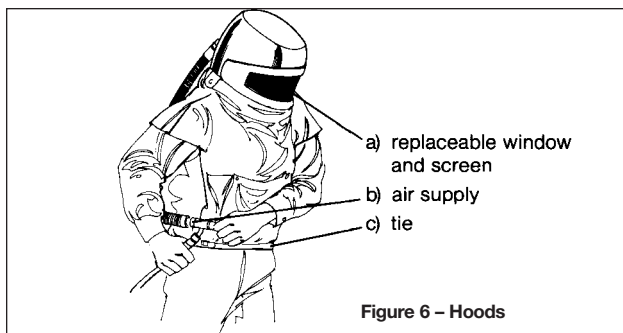

Figure 6 – Hoods

Class 6 – Face Shields (Figure 7)

Face shields are just what the name implies—a device that includes a transparent window or visor to shield the face and eyes from impact, splash, heat, or glare. With face shields, as with welding helmets and hand shields, the user is continually lifting and lowering the visor. To protect the eyes when the visor is lifted, Class 1 spectacles should be worn underneath. Face shields may also be equipped with an adjustable spark deflector or brow guard that fits on the worker's hard hat. Shaded windows are also available to provide various degrees of glare reduction; however, they do not meet the requirements of CSA Standard Z94.3-99 *Industrial Eye and Face Protectors* for ultraviolet and total heat protection and should not be used in situations where any hazard is present from ultraviolet or infra-red radiation.

Class 6

This class includes

- 6A for impact and splash protection
- 6B for radiation protection
- 6C for high-heat applications.

Figure 7 – Face Shields

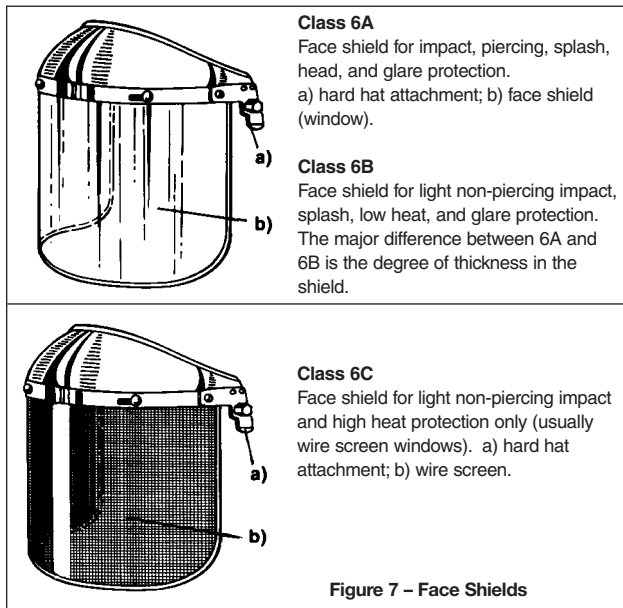

Class 6A
Face shield for impact, piercing, splash, head, and glare protection.
a) hard hat attachment; b) face shield (window).

Class 6B
Face shield for light non-piercing impact, splash, low heat, and glare protection. The major difference between 6A and 6B is the degree of thickness in the shield.

Class 6C
Face shield for light non-piercing impact and high heat protection only (usually wire screen windows). a) hard hat attachment; b) wire screen.

Figure 7 – Face Shields

Class 7 – Respirator Facepieces (Figure 8)

This class includes

- 7A for impact and splash protection
- 7B for radiation protection
- 7C with loose-fitting hoods or helmets
- 7D with loose-fitting hoods or helmets for radiation protection.

Figure 8 – Respirator Facepieces

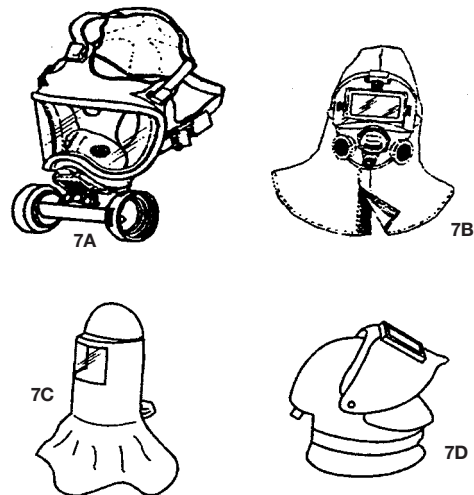

Hazards and Recommended Protectors

Reprinted from CSA Standard Z94.3-99 *Industrial Eye and Face Protectors*, Table 1 classifies the main eye hazards and outlines the types of protectors recommended for each. Each situation requires that all hazards be considered in selecting the appropriate protector or combination of protectors.

The practice of requiring all personnel to wear spectacles is strongly recommended. Spectacles should be worn underneath Classes 3, 4, 5, 6, or 7 protectors, where the hazard necessitates the use of spectacles.

The following classifications provide a general overview of eye protectors for each hazard group. For specific hazards, refer to Table 1. Note that the best eye protection results from a combination of different classes of eye protectors.

Group A: Flying Objects (Figure 9)

Minimum eye protection recommended:
Class 1 spectacles

Optimum eye protection recommended:
Goggles worn with face shields to provide eye and face protection.

Group B: Flying Particles, Dust, Wind, etc. (Figure 10)

Minimum eye protection recommended:
Class 1 spectacles

Optimum eye protection recommended:
Goggles (for dust and splash) worn with face shields to provide eye and face protection.

Group C: Heat, Glare, Sparks, and Splash from Molten Metal (Figure 11)

Minimum eye protection recommended:
Class 1 spectacles with filter lenses for radiation protection. Side shields must have filtering capability equal to or greater than the front lenses.

Optimum eye protection recommended:
Eyecup or cover goggles with filter lenses for radiation protection, worn with face shields to provide eye and face protection.

**Table 1
Hazards and Recommended Protectors**

| Hazard groups | Nature of hazard | Hazardous activities involving but not limited to | Spectacles Class 1 | | Goggles Class 2 | | | Welding helmet Class 3 | Welding hand shield Class 4 | Face shields Class 6 | | | Non-rigid hoods Class 5 | | | | |
|---------------|---|---|--------------------|---|-----------------|---|---|------------------------|-----------------------------|----------------------|---|---|-------------------------|---|---|---|--|
| | | | A | B | A | B | C | | | A | B | C | A | B | C | D | |
| A | Flying objects | Chipping, scaling, stonework, drilling; grinding, buffing, polishing, etc.; hammer mills, crushing; heavy sawing, planing; wire and strip handling; hammering, unpacking, nailing; punch press, lathework, etc. | | | | | | | | | | | | | | | |
| B | Flying particles, dust, wind, etc. | Woodworking, sanding; light metal working and machining; exposure to dust and wind; resistance welding (no radiation exposure); sand, cement, aggregate handling; painting; concrete work, plastering; material batching and mixing | | | | | | | | | | | | | | | |
| C | Heat, sparks, and splash from molten materials | Babbling, casting, pouring molten metal; brazing, soldering; spot welding, stud welding; hot dipping operations | | | | | | | | | | | | | | | |
| D | Acid splash; chemical burns | Acid and alkali handling; degreasing, pickling and plating operations; glass breakage; chemical spray; liquid bitumen handling | | | | | | | | | | | | | | | |
| E | Abrasive blasting materials | Sand blasting; shot blasting; shotcreting | | | | | | | | | | | | | | | |
| F | Glare, stray light (where reduction of visible radiation is required) | Reflection, bright sun and lights; reflected welding flash; photographic copying | | | | | | | | | | | | | | | |
| G | Injurious optical radiation (where moderate reduction of optical radiation is required) | Torch cutting, welding, brazing, furnace work; metal pouring, spot welding, photographic copying | | | | | | | | | | | | | | | |
| H | Injurious optical radiation (where large reduction of optical radiation is required) | Electric arc welding; heavy gas cutting; plasma spraying and cutting; inert gas shielded arc welding; atomic hydrogen welding | | | | | | | | | | | | | | | |

Note: Shaded areas are recommendations for protectors. Class 1 and Class 2 protectors shall be used in conjunction with recommendations for Class 3, 4, 5, and 6 protectors. The possibility of multiple and simultaneous exposure to a variety of hazards shall be considered in assessing the needed protection. Adequate protection against the highest level of each of the hazards should be provided. This Table cannot encompass all of the various hazards that may be encountered. In each particular situation, thorough consideration should be given to the severity of all the hazards in selecting the appropriate protector or combination of protectors. The practice of wearing protective spectacles (Class 1B) with filter lenses under welding helmets or hand shields is strongly recommended to ensure impact and flash protection to the wearer when the helmet or lift front is raised or the shield is not in use. Protectors that meet the requirements for ignition and flame resistance are not intended to provide protection in environments that expose the user to open flames or high-energy arcs. Courtesy Canadian Standards Association

Table 2
Recommended Shade Numbers for Arc Welding and Cutting

| Operation | Current in amperes | | | | | | | | | | | | | | | | | | | | | | |
|------------------------------|--------------------|-----|-----|-----|----|----|----|----|----|----|----|-----|-----|-----|-----|-----|-----|-----|-----|-----|-----|-----|-----|
| | 0.5 | 1.0 | 2.5 | 5.0 | 10 | 15 | 20 | 30 | 40 | 60 | 80 | 100 | 125 | 150 | 175 | 200 | 225 | 250 | 275 | 300 | 350 | 400 | 450 |
| SMAW (covered electrodes) | 7 | | | | | 8 | | | | | 10 | | | | | 11 | | | | | | | |
| GMAW (MIG) | 7 | | | | | 10 | | | | | 10 | | | | | 10 | | | | | | | |
| GTAW (TIG) | 8 | | | | | 8 | | | | | 10 | | | | | | | | | | | | |
| Air carbon arc cutting | 10 | | | | | | | | | | | | | | | | | | | | | | |
| Plasma arc cutting | | | | | | 8 | | | | | 9 | | | | | 10 | | | | | | | |
| Plasma arc welding | 6 | | | | | 8 | | | | | 10 | | | | | 11 | | | | | | | |

Notes:

- (1) For other welding processes (e.g., laser, electron beam welding), consult the manufacturer for eye protection recommendations.
- (2) For pulsed GMAW (MIG), use peak current for selecting the appropriate shade number.
- (3) For underwater welding, the minimum shade number shown may not necessarily apply.

Courtesy Canadian Standards Association

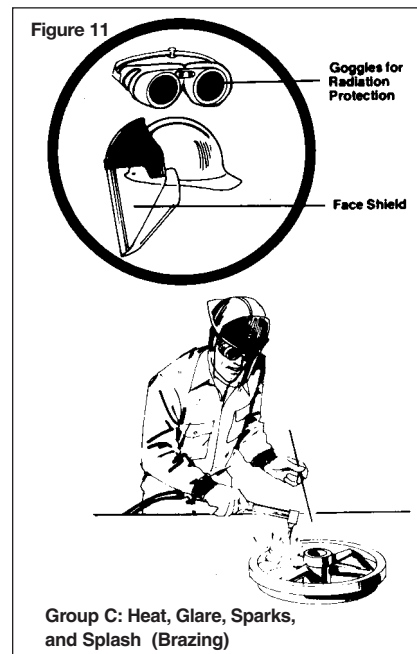
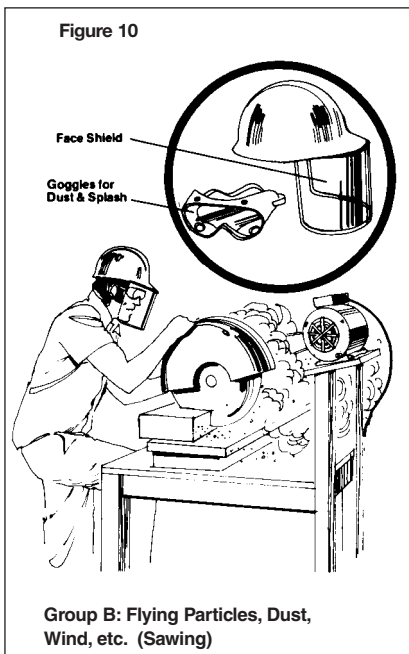
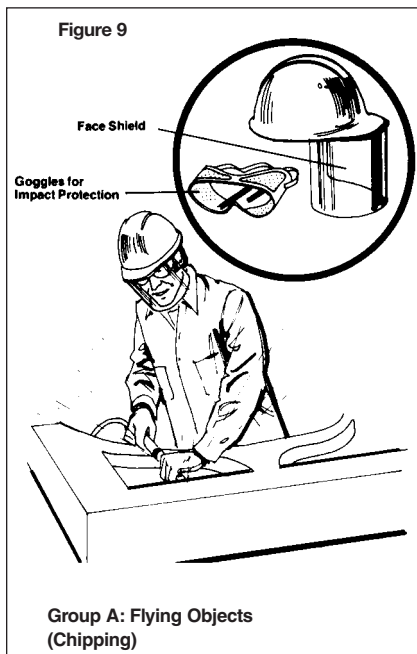

Group D: Acid Splash, Chemical Burns, etc. (Figure 12)

Only eye protection recommended:

Eye cup or cover goggles (for dust and splash) worn with face shields to provide eye and face protection.

Hoods may also be required for certain hazardous activities such as chemical spraying.

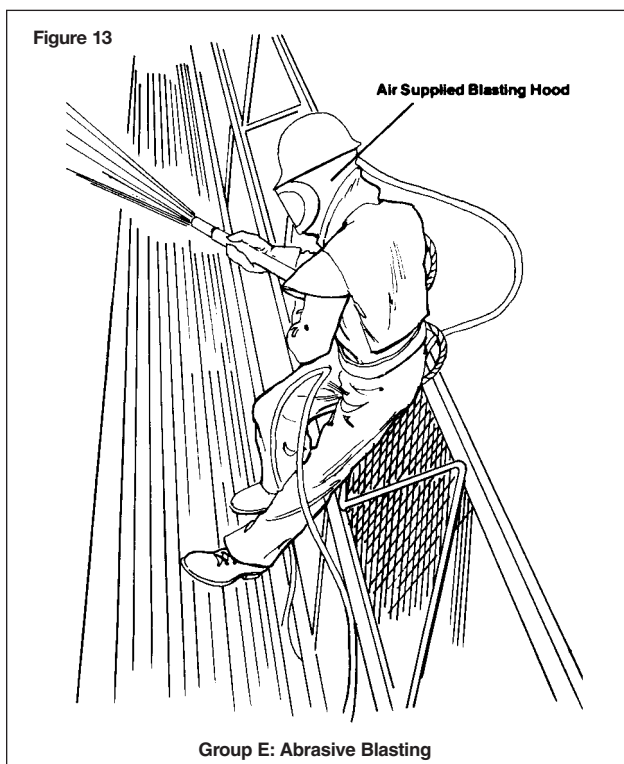
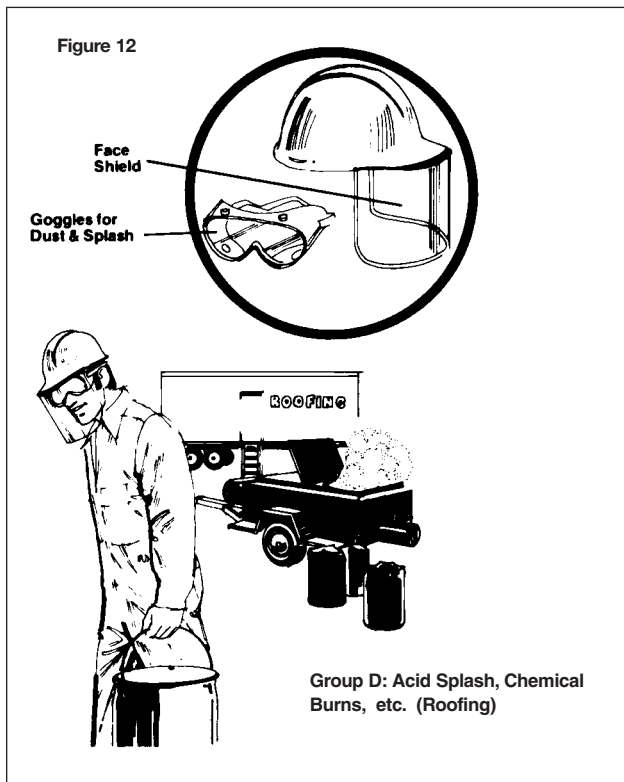

Group E: Abrasive Blasting Materials (Figure 13)

Minimum eye protection recommended:

Eye cup or cover goggles for dust and splash.

Optimum eye protection recommended:

Hoods with an air line.

Group F: Glare, Stray Light (Figure 14)

These are situations where only slight reduction of visible light is required, e.g., against reflected welding flash. Stray light would result from passing by a welding operation and receiving a flash from the side without looking directly at the operation.

Minimum eye protection recommended:

Filter lenses for radiation protection. Side shields must have filtering capability equal to or greater than the front lenses.

Optimum eye protection recommended:

Goggles with filter lenses for radiation protection. See Table 2 for recommended shade numbers.

Group G: Injurious Radiation (Figure 15)

These are situations where only moderate reduction of visible light is required: for example, gas welding. Injurious radiation would result from looking directly at the welding operation.

Only eye protection recommended:

Goggles with filter lenses for radiation protection.

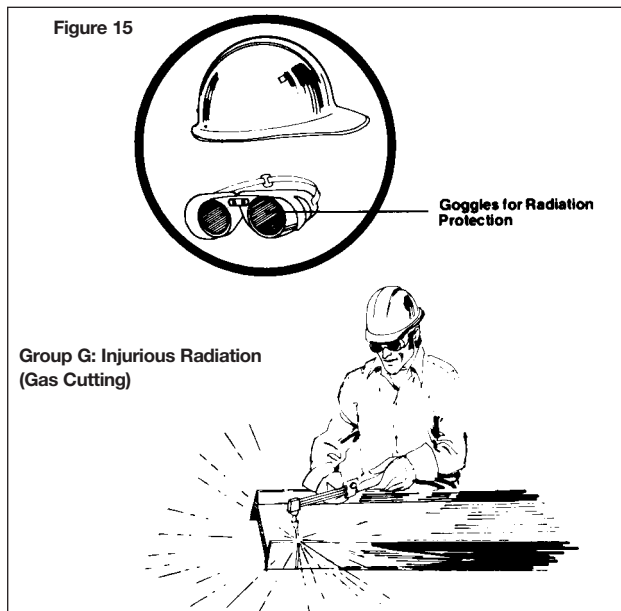
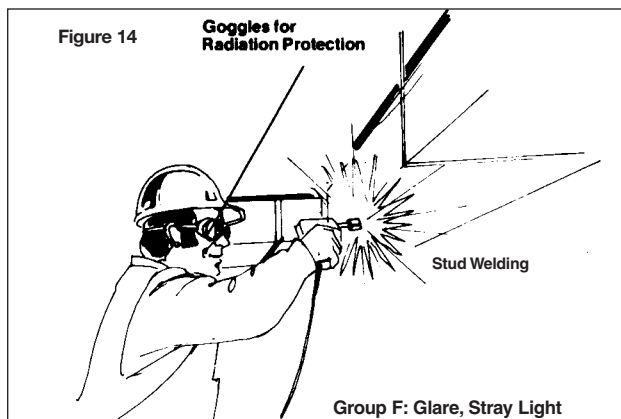

Note: The intensity of the flame and arc is lower in Group G than in Group H. For this reason, required filter shade numbers for this group are also lower. See Table 2.

Group H: Injurious Radiation (Figure 16)

These are situations where a large reduction in visible light is essential, e.g., in electric arc welding.

Only eye protection recommended:

Class 1 spectacles worn with full welding helmets or welding hand shields. These spectacles should incorporate suitable filter lenses if additional protection is required when the welding helmet is in the raised position: for example, when working near other welding operations. See Table 2.

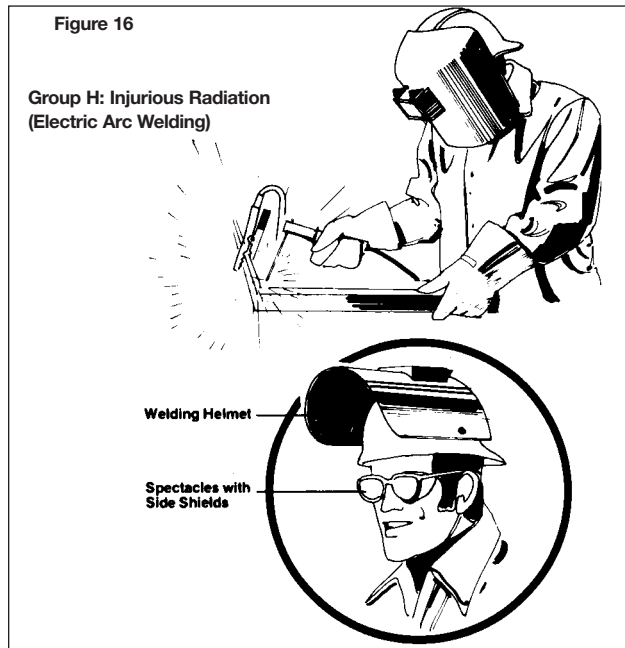

Injuries Associated with Construction Hazards

The cornea is the front layer of the eye and the first point at which light enters the eye; if light rays cannot pass through the cornea, vision is prevented. Injuries to the cornea that cause scarring, scratching, or inflammation can impair sight.

1. Flying Objects

A piece of metal can pierce the cornea and eyeball and possibly cause the loss of an eye.

2. Dust

Dust, sawdust, etc. can cause irritation resulting in a corneal ulcer which is a breakdown of corneal tissue causing a red, watery, or pussy eye.

3. Heat

Heat can burn and severely damage the cornea.

4. Acid Splash

Acid splash and chemicals can burn the cornea, conjunctiva (white coat on the eye), and eyelid and possibly cause loss of sight.

5. Abrasive

Sand can cause a corneal abrasion which can result in loss of sight.

6. Glare

Glare can make it difficult to see and can cause extreme fatigue to the eye.

7. Radiation

Ultraviolet light from a welding arc can damage the cornea.

Correct eye protection, when matched to the hazard, can prevent or reduce the degree of any eye injury. However, once an eye injury has occurred, it is critical that the injury, no matter how small, be given immediate attention and first aid.

Eye protection can only protect against injury if it is worn continuously on-site.

It is often the time when a worker removes eye protection while working near or passing by other hazardous activities on the job that an eye injury results. When it is necessary to remove eye protection, do so only in a location that is completely away from hazardous work areas.

The inconvenience of wearing eye protection is far outweighed by the risk of being blinded in one or both eyes.

Purchase of Protective Spectacles

Protective spectacles are available with “plano” or non-prescription lenses and with prescription lenses.

The polycarbonate materials used in safety glasses provide the best protection, while regular plastic CR-39 lenses in industrial thickness provide a substitute where polycarbonate is not available. Anti-scratch coatings are applied to the lens surface to extend useful lens life.

Glass lenses, even when thermally or chemically hardened, are not acceptable for the workplace. Current glass lenses do not meet the impact requirements of CSA Standard Z94.3-99.

When purchasing safety glasses, specify **industrial protection** lenses and frames. This term indicates that the eye protection meets specific test requirements.

Industrial protection safety glasses can be identified by the manufacturer’s or supplier’s logo or monogram which is located on the lens and frame (Figure 17).

Figure 17 – Where to Locate Identification Marks or Symbols

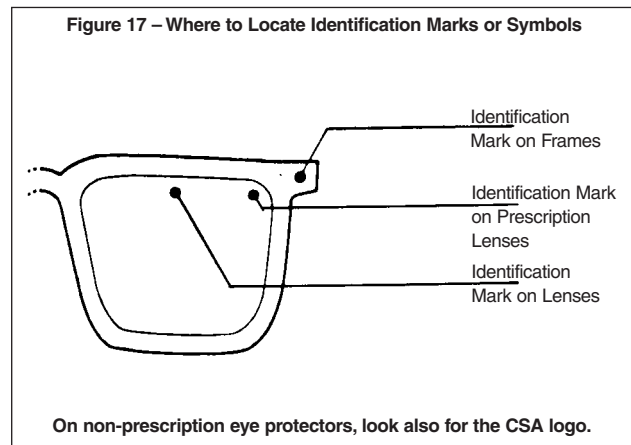

This mark must appear on both the frame **and** the lens. It distinguishes industrial quality lenses and frames from streetwear lenses and frames.

The Canadian Standards Association (CSA)



certification program for non-prescription (plano) industrial eye and face protection covers complete protectors only. It does not cover separate components such as lenses, frames, or shields.

In addition to the manufacturer's logo or I.D. mark which appears on the eye protector, the CSA logo will appear to indicate the eye protection meets the requirements of the CSA Z94.3-99 standard. Certification of industrial prescription safety glasses is not yet available.

Until such a program is available, the user should look for the manufacturer's or supplier's logo or I.D. mark on the frame and lens which indicates adherence to the American National Standards Institute (ANSI) Standard Z87.1-1989.

Fitting

Improper fit is the most common reason for resistance to wearing eye protection. A worker who wears non-prescription (plano) lenses and continues to complain about blurred vision after the fit has been checked by a competent person may require prescription lenses. Prescription lenses must be fitted by an optician or optometrist. Plano eye protection should be fitted individually by a trained person.

Here are some general guidelines to follow when fitting the various classes of eye protectors.

Class 1 – Spectacles require that the proper eye size, bridge size, and temple length be measured for each individual. The wearer should be able to lower his head without the spectacles slipping.

Class 2 – Goggles with adjustable headbands should fit snugly over the wearer's spectacles when worn.

Class 3 – Welding helmets are equipped with adjustable attachments to provide a comfortable fit over the head and face. Attachments are also available to fit on hard hats.

Class 4 – Hand-held shields require no adjustment.

Class 5 – Hoods Adjustments are located on the top inside of the hood. A tie is located around the neck to secure the hood and to prevent the entry of dust.

Class 6 – Face shields are equipped with adjustable attachments to provide a comfortable fit over the head and face. Attachments are also available to fit on hard hats.

Class 7 – Respirator facepieces should fit snugly without gaps to make an effective seal against airborne contaminants.

Care

Eye protectors in construction are subjected to many damage-causing hazards. Therefore, care is very important.

1. Lenses should be inspected regularly for pitting and scratches that can impair visibility.
2. Scratched or pitted lenses and loose frames or temples should be replaced or repaired as soon as possible with components from the original manufacturer.

3. Lenses should be cleaned with clear water to remove abrasive dust—cleaning dry lenses can scratch the surface.
4. Anti-fog solutions can be used on glass or plastic lenses.
5. Frames should be handled with care and checked daily for cracks and scratches.
6. Eye protectors should never be thrown into tool boxes where they can become scratched or damaged.
7. Cases should be provided and used to protect spectacle lenses when not being worn.

Contact Lenses

In the construction industry, contact lenses are not a substitute for protective eyewear. Dust and dirt can get behind the contact lenses causing sudden discomfort and impairment of vision.

Contact lenses are also difficult to keep clean when they have to be removed or inserted since there are seldom suitable washing-up facilities on a jobsite.

It is recommended that contact lenses not be worn on construction sites.

However, in cases where contact lenses must be worn to correct certain eye defects, workers should obtain from their ophthalmologist or optometrist written permission indicating the necessity of wearing contact lenses in order to function safely at work. In these cases eye protection, preferably cover goggles, must be worn with the contact lenses.

HEAD PROTECTION Standards

Requirements for head protection are specified in the current edition of the construction regulation (O. Reg. 213/91).

Under this regulation, hard hats are mandatory for all construction workers on the job in Ontario. The hard hat must protect the wearer's head against impact and against small flying or falling objects, and must be able to withstand an electrical contact equal to 20,000 volts phase to ground.

At the present time, the Ministry of Labour (MOL) considers the following classes of hard hats to be in compliance with the regulation.

Class B

- manufactured and tested in accordance with CSA Standard Z94.1-1977

Class B

- manufactured and tested in accordance with ANSI Z89.1-1986

Type I, Class E

- manufactured and tested in accordance with ANSI Z89.1-1997.

Class E

- manufactured and tested in accordance with CSA Standard Z94.1-1992

Type II, Class E

- manufactured and tested in accordance with ANSI Z89.1-1997.

"Type" and "Class" of hard hat can be identified by the CSA or ANSI label. Some manufacturers also stamp the CSA or ANSI classification into the shell of the hard hat under the brim.

Styles

New Class E hard hats come in three basic styles:

- 1) standard design with front brim, rain gutter, and attachment points for accessories such as hearing protection
- 2) standard design with front brim and attachment points for accessories but without a rain gutter
- 3) full-brim design with attachment points for accessories and brim that extends completely around the hat for greater protection from the sun.

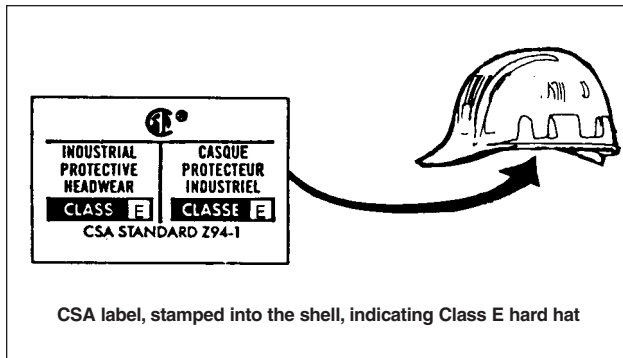

FOOT PROTECTION

Ankle injuries represent 50% of all foot injuries in Ontario construction. Properly worn, a CSA-certified Grade 1 workboot meets the requirements of the current construction regulation (O. Reg. 213/91) and helps protect against ankle and other injuries.

One of three CSA grades, Grade 1 offers the highest protection and is the only one allowed in construction. In a Grade 1 boot, a steel toe protects against falling objects while a steel insole prevents punctures to the bottom of the foot.

Grade 1 boots can be identified by

- a green triangular patch imprinted with the CSA logo on the outside of the boot and
- a green label indicating Grade 1 protection on the inside of the boot.

Grade 1 boots are also available with metatarsal and dielectric protection. A white label with the Greek letter Omega in orange indicates protection against electric shock under dry conditions.



Selection and Fit

Grade 1 boots are available in various styles and sole materials for different types of work. For example, Grade 1 rubber boots may be better suited than leather boots for sewer and watermain or concrete work.

Boots should provide ample "toe room" (toes about 1/2 inch back from the front of steel box toe cap when standing with boots laced).

When fitting boots, allow for heavy work socks. If extra sock liners or special arch supports are to be worn in the boots, insert these when fitting boots.

Care and Use

Lacing boots military style permits rapid removal. In an emergency, the surface lace points can be cut, quickly releasing the boot.

In winter, feet can be kept warm by wearing a pair of light socks covered by a pair of wool socks. Feet should be checked periodically for frostbite.

Use high-cut (260 mm or 9 in) or medium-cut (150 mm or 6 in) CSA Grade 1 workboots. The higher cut helps support the ankle and provides protection from cuts or punctures to the ankle.

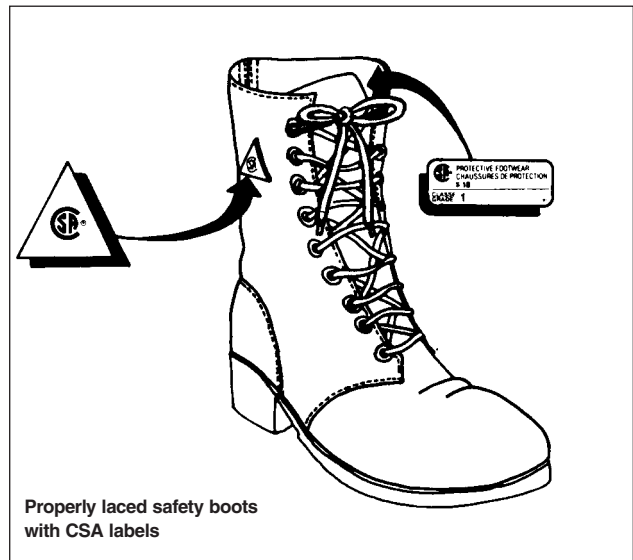

HEARING PROTECTION

Introduction

Construction generally produces noise. Typical construction work may involve equipment driven by large and small engines, metal fabrication, power drilling and sawing, air hammering, and blasting – all of which can produce noise at harmful levels.

Depending on the noise level, duration of exposure, and other factors, a temporary or permanent hearing loss may result. Temporary hearing losses will usually be restored by the body within a few hours after the exposure has ceased. Hearing losses which cannot be restored by the body over any length of time are termed permanent.

A person suffering a hearing loss will frequently not realize it. Noise may be harmful at levels that an exposed person does not consider irritating or annoying. Therefore, despite **individual** preferences, prevention and control procedures must be based on the **general** potential for hearing loss.

Waiting for personal discomfort before taking preventive measures may be too late to avoid a permanent noise-induced hearing loss.

Noise Measurement

Measuring sound levels can determine

- whether or not a noise hazard is present
- noise exposures of workers
- which workers require hearing protection, hearing tests, education, and training.

Measurements are performed with a sound level meter (SLM). The unit used to measure the intensity of sound is the decibel (dB). Intensity is perceived as loudness.

Noise levels can't be added directly like other numbers. For example, two noise sources producing 90 dB each would have a combined output of 93 dB, not 180 dB. The combined output of 93 dB is actually a *doubling* of intensity.

In many construction situations several different sources each contribute to the overall noise. This means that a worker's exposure may be much higher than it would be if only one of the sources was present (Figure 1).

In addition to intensity, the SLM can detect a wide range of frequencies. Since the human ear tends to filter out the lower frequencies and slightly accentuate the higher ones, SLMs are engineered to do the same. They feature an internal mechanism called "A-weighting." The resulting noise level is expressed as decibels (dB) on the "A" scale or dBA.

Two types of noise measurements can be performed: area and personal.

An **area noise measurement** is taken in a specific work area. The measurement is generally used as a preliminary step to determine whether more detailed evaluation involving personal noise measurement is necessary. Area noise readings should not be used to determine what hearing protection is required or who needs a hearing test. Personal exposure measurement should be used for these purposes.

Personal noise measurement involves a small device called a noise dosimeter. Workers can wear the device to determine their average noise exposure over a whole shift. Usually worn around the waist, the dosimeter has a microphone that is placed as close to the worker's ear as possible.

Noise measurements should be carried out in accordance with acceptable standards. Canadian Standards Association (CSA) Standard Z107, *Procedures for the Measurements of Occupational Noise Exposure*, provides guidance on the type of equipment to use, which workers to test, and how to test.

Noise evaluation must be done by a knowledgeable person trained and experienced in conducting noise surveys.

Hearing Process

The hearing process begins when the outer ear directs sound waves into the ear canal (Figure 2). The eardrum vibrates as sound waves strike it. This vibration is then transmitted through the middle ear where it is amplified on a membrane called the oval window. The oval window separates the middle ear from the inner ear where the sensitive hearing organs are located. Attached to the other side of the oval window is a tiny, snail-shaped structure called the cochlea. The cochlea contains fluid and hair cells. These thousands of small but highly sensitive hair cells feel the vibration. Responding to the cells are microscopic nerve endings that send messages to the brain, where the signals are interpreted as varieties of sound.

Hearing Loss

Any reduction in the normal ability to hear is referred to as a loss of hearing. A hearing loss can be either temporary or permanent.

Temporary Threshold Shift

With a temporary hearing loss, normal hearing will usually return after a rest period away from all sources of intense or loud noise. The recovery period may be minutes, hours, a day or perhaps even longer. It is believed that a temporary hearing loss occurs when hair cells in the inner ear have been bent by vibrations and need time to bounce back.

Most of the temporary hearing loss occurs during the first two hours of exposure and recovery takes place usually within the first two hours after exposure stops.

Figure 1

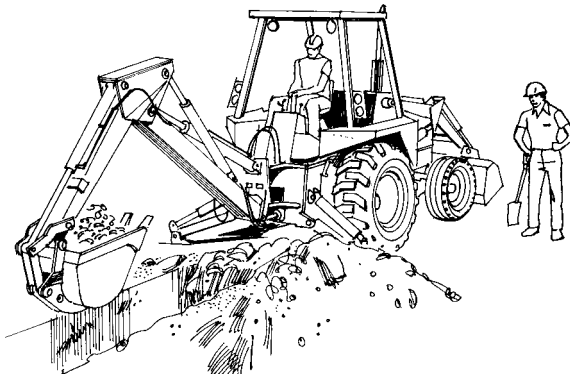

The backhoe is producing 90 dB of noise. The worker standing nearby is therefore exposed to 90 dB.



The backhoe is producing 90 dB. The compressor is also producing 90 dB. The worker standing between the two pieces of equipment is therefore exposed to their combined output. This double intensity is 93 dB.

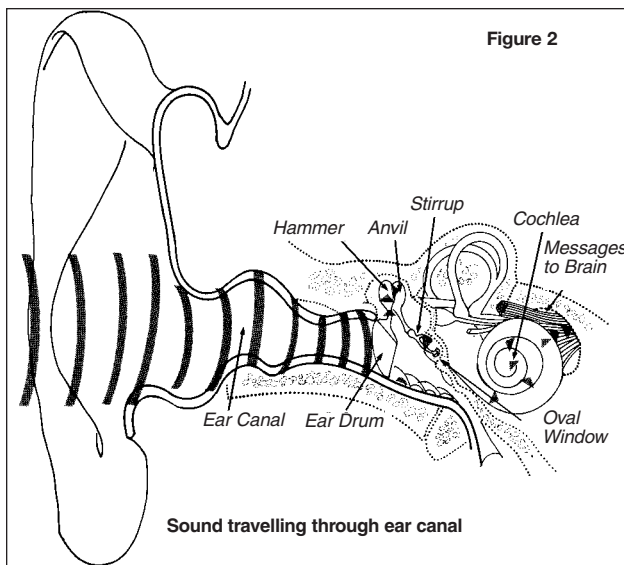

However, the length of time needed for recovery depends primarily on how great the initial loss was. The greater the initial loss the longer the time needed to recuperate. This temporary decrease in hearing ability is called a temporary threshold shift (TTS) because the threshold or level at which sound can be heard has been raised.

For instance, to listen to your favourite music at the volume you like, you would have to turn it up a few more notches than usual. This phenomenon explains why some people, particularly those who suffer from some form of hearing loss, claim that they “get used to the noise.”

If these previous exposures are allowed to continue under the same conditions and without the proper interval of rest, then a certain degree of permanent hearing loss is possible.

Permanent Threshold Shift

Permanent hearing loss is the result of hair cell or nerve destruction within the cochlea. Once these important parts of the hearing process are destroyed, they can never be restored or regenerated. The resulting permanent hearing loss, also referred to as permanent threshold shift (PTS), can range from slight impairment to nearly total deafness.

A symptom of PTS is the inability to pick up sounds with higher frequencies. As damage increases, the reception of speech becomes more difficult.

Unfortunately, the damage builds up gradually. Workers may not notice changes from one day to another. But once the damage is done there is no cure. Effects may include the following.

- Sounds and speech become muffled so that it's hard to tell similar-sounding words apart or to pick out a voice in a crowd.
- Sufferers ask people to speak up, then complain that they are shouting.
- There's a permanent ringing in the ears (tinnitus).
- Sufferers need to turn the volume on the radio or television way up or find it hard to use the telephone.

Determining Factors

The following factors determine the degree and extent of hearing loss:

- **Type of Noise**
(continuous, intermittent, impact, high or low frequency)
- **Intensity of Noise**
(level of loudness)
- **Duration of Exposure**
(length of time worker subjected to noise – for example, during day, on specific shifts)
- **Employment Duration**
(years worker subjected to noise)
- **Type of Noise Environment**
(character of surroundings – for example, enclosed, open, reflective surfaces)
- **Source Distance(s)**
(distance of worker from noise source)
- **Worker's Position**
(position of worker relative to noise source)
- **Worker's Age**
(for instance, a 20-year-old apprentice versus a 50-year-old journey person)
- **Individual Susceptibility**
(sensitivity difference, physical impairments)
- **Worker's Present Health**
(whether a worker has any detectable losses or ear diseases)
- **Worker's Home and Leisure Activities**
(exposures to noise other than occupational, such as hunting, skeet shooting, earphone music, snowmobiling, etc.)

Other prime causes of permanent hearing loss are age, traumatic injuries (such as from explosions or gunfire), and infection.

Noise, however, is the major identifiable cause of hearing loss. Therefore, it is important that controls are exercised wherever possible so that such losses can be prevented.

Hearing Protection

One form of controlling noise hazards is through the proper use of hearing protection devices (HPDs). Hearing protectors should be provided when engineering controls cannot be implemented or while such controls are being initiated.

Hearing protective devices are barriers that reduce the amount of noise reaching the sensitive inner ear. Fit, comfort, and sound reduction or “attenuation” are important considerations in choosing HPDs.

Commonly used hearing protection devices are either earplugs or earmuffs. Earplugs attenuate noise by plugging the ear canal (Figure 3). The muff-type protector is designed to cover the external part of the ear providing an “acoustical seal” (Figure 4). Table 1 describes some of the characteristics of these different types of hearing protectors.

Effectiveness

Obviously, the effectiveness of an HPD depends on the amount of time it is worn. What is not obvious to most wearers is the drastic reduction in protection if HPDs are not worn in noisy environments even for short periods of time.

Figure 3

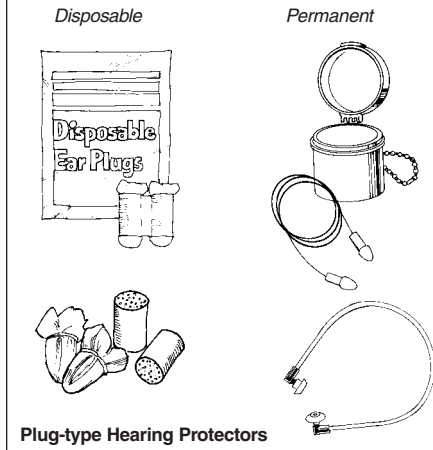

The reduction in effectiveness can be as great as 95% or more if the protectors are not worn for as little as three or four minutes. It is therefore important to wear HPDs during the entire noise exposure period in order to achieve the maximum protection available.

The effectiveness of HPDs also depends on the manner in which noise is transmitted through or around the protector. The following points should be noted.

- Even relatively small openings or air leaks in the seal between the hearing protector and the skin can typically reduce attenuation by 5 to 15 dB or more.
- Constant movement of the head or body vibration can lead to air leaks, therefore making periodic adjustments necessary to ensure a proper seal.
- Hair, especially long hair and facial hair, can cause a poor fit.
- Proper fitting is crucial to obtaining a reasonable degree of protection from an HPD.
- Earmuff effectiveness is greatly influenced by headband tension. If tension decreases through routine usage or alteration by the user, earmuff effectiveness is reduced.
- Modifying the earmuff by drilling holes in the earcups renders the protection useless.
- Anatomical differences such as ear canal size, jaw size, and heads of different shape and size may affect the fit of earmuffs and earplugs. To accommodate these differences, HPDs should be made available to users in various shapes and sizes.
- Recreational headsets such as those used with radios and CD players are **not** to be used as hearing protection.

Selection Criteria

In addition to attenuation characteristics, the following factors should be considered when selecting hearing

Figure 4

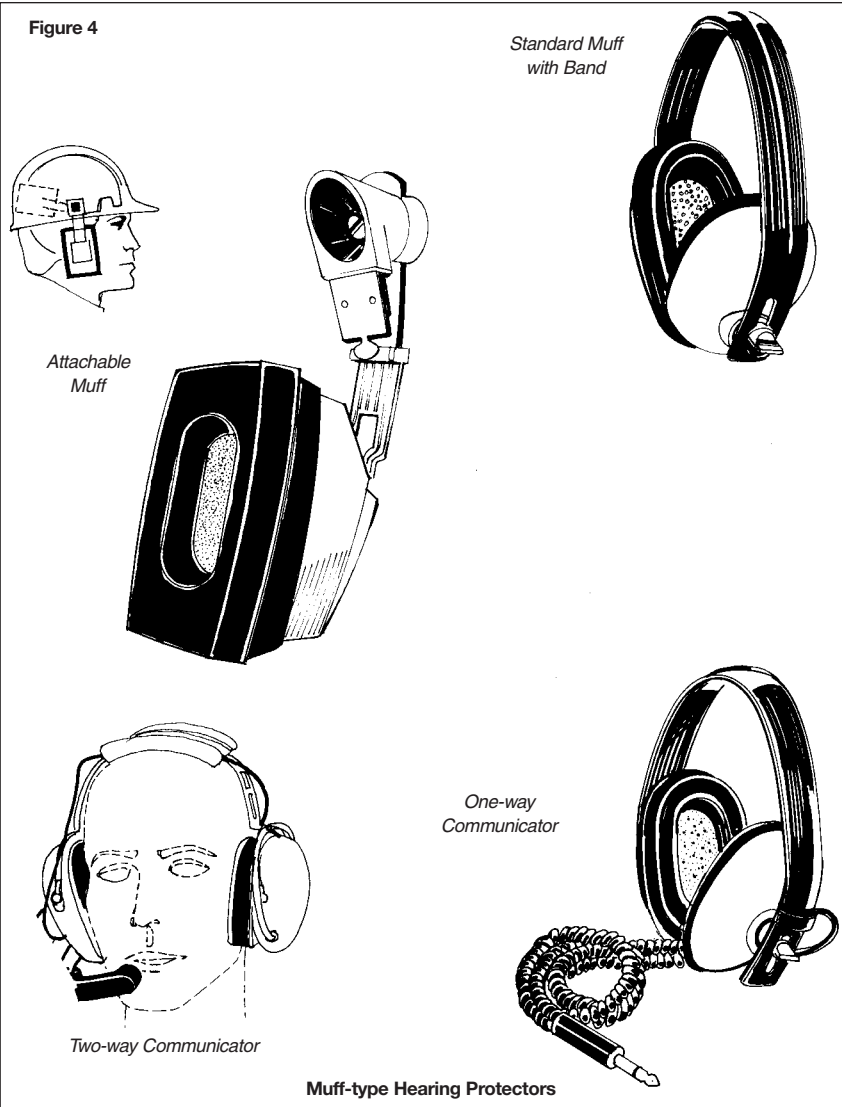

protectors:

- noise exposure levels and standards
- comfort
- appearance
- communication requirements
- work environment or work procedures
- overprotection.

Noise Exposure Levels and Standards

Identifying the noise level(s) to which an individual may be exposed throughout an entire working day determines the class of hearing protector needed.

Evaluation is based on eight-hour noise exposure, not a spot or area measurement. For example, a quick-cut saw operated by a mason may produce a noise level of 110 dBA. But the mason may only be exposed to an average of 92 dBA over the full eight-hour shift. The reason is that the saw is not operated continuously during that period. There will be times when the worker is laying brick, taking a coffee break, or eating lunch.

CSA Standard Z94.2, *Hearing Protectors*, identifies classes of hearing protectors as A, B, and C. Protectors are classed by attenuation ability under laboratory

Table 1: Types of Hearing Protectors





| | FOAM EARPLUGS | PREMOULDED EARPLUGS | EARMUFFS | FORMABLE EARPLUGS | CUSTOM-MOULDED EARPLUGS | SEMI-INSERT EARPLUGS |
|--------------------------|--|--|--|--|--|---|
| |  |  |  |  |  |  |
| STYLE and COMFORT | Consist of compressible plastic foam. Come in many shapes. Often described as “disposable plugs.” Elasticity lets them adapt easily to changes in ear canal. | Usually made of plastic or silicone rubber attached to a flexible stem for handling and insertion. Come in many shapes and sizes to suit different ear canals. | Consist of two insulated plastic cups attached to metal or plastic band. Cups equipped with soft cushions for seal and comfort. Head band tension ensures good seal. | Made from pliable material such as cotton/wax mixture, silicone putty, and mineral wool. | Custom made to fit a particular ear by taking an impression of the ear, making a mould, and casting a plug. | Commonly known as banded earplugs or canal caps. They consist of small caps or pods that are held in place over the ear canal by spring-loaded bands. |
| INTENDED USE | Most brands can be reused a few times before being discarded. | To be used more than once. | To be used regularly. Can be worn with or without plugs. Easily attached to hard hats. | <ul style="list-style-type: none"> • Single-use for mineral wool products. • Multi-use for cotton/wax products. • Semi-permanent for silicone putty products. | Permanent use | To be used more than once. |
| HYGIENE PRACTICES | Clean hands required each time fresh plugs inserted. | Plugs should be cleaned regularly with warm soapy water, preferably after each removal from ear. | General maintenance required. Head band must be maintained. Cushions must be replaced when soiled or brittle. | Clean hands required for shaping and insertion. | Wash with hot water and soap, preferably after removal. | Wash with hot water and soap, preferably after removal. |
| ADVANTAGES | Low risk of irritation. One size fits most workers. | Reusable. | Less likely to cause irritation. When attached to hard hat, always available for use. | Relatively cheap | Good fit only if a proper impression of the ear is taken. | Good for when frequent removal is required. |
| DISADVANTAGES | Use requires clean hands. Large supply required for frequent removals and usage. | Plugs must be kept clean to prevent irritation. May produce some discomfort with pressure. Though reusable, plugs degrade over time. Inspect and replace as necessary. | Bands may wear out and tension decrease. Eyewear and hair may interfere with fit and reduce protection. | Not recommended for the noise levels found on construction projects. | If the wearer’s weight changes drastically, new plugs should be made. Plugs can be lost, shrink, harden, or crack over time, and must be replaced. | Proper seal is necessary for good attenuation. |

Table 2

| MAXIMUM NOISE LEVEL (dBA) | RECOMMENDED CLASS OF HEARING PROTECTOR |
|---------------------------|---|
| Less than 85 dBA | No protection required |
| Up to 89 dBA | Class C |
| Up to 95 dBA | Class B |
| Up to 105 dBA | Class A |
| Up to 110 dBA | Class A plug + Class A or Class B muff |
| More than 110 dBA | Class A plug + Class A or Class B muff and limited exposure |

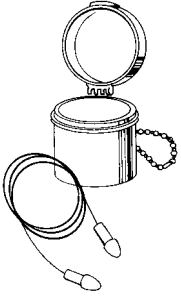
Recommended criteria for selecting a class of hearing protector, based on a daily 8-hour exposure to noise levels in dBA. Adapted from CSA Standard Z94.2-M1984.

conditions modified by certain practical field considerations. Class A protectors offer the highest ability to attenuate, followed by B and C.

Table 2 provides guidelines for proper selection. Table 3 lists typical noise levels for various kinds of construction equipment. The upper limits of the noise levels can be used as a guide in selecting a specific class of hearing protectors.

Comfort

Comfort is an important consideration in selection. An HPD that isn't comfortable will simply not be worn or will be worn improperly.

With earplugs several factors affect comfort. Since some plugs are relatively non-porous they can often create a pressure build-up within the ear and cause discomfort. Dirty plugs may irritate the ear canal. The shape of an individual's ear canals may not allow certain plugs to fit properly.

Earmuffs should be made of materials which do not absorb sweat and which are easy to maintain and clean. The earmuff cup should be adjustable to conform to various head sizes and shapes. Headband tension and earcup pressure should be adjusted so that they are effective without being uncomfortable. Weight may also be a factor.

Workers should be allowed to try out various HPDs to determine which are most comfortable.

Appearance

HPD appearance may influence selection. Those that look bulky or uncomfortable may discourage potential users. Allowing workers to select from various HPDs, or various makes of the same HPD, can help overcome this problem.

Speech Requirements

Consider the level of the noise hazard and the risks of impaired communication (Table 4). The potential for speech interference is greatest when background noise – meaning all noises generated in the surrounding area – is

Table 3

| TYPICAL NOISE LEVEL MEASUREMENTS FOR CONSTRUCTION | |
|---|--|
| * EQUIPMENT | NOISE LEVEL (DBA) AT OPERATOR'S POSITION |
| Cranes | 78 – 103 |
| Backhoes | 85 – 104 |
| Loaders | 77 – 106 |
| Dozers | 86 – 106 |
| Scrapers | 97 – 112 |
| Trenchers | 95 – 99 |
| + Pile drivers | 119 – 125 |
| Compactors | 90 – 112 |
| + Explosive-actuated tools | 120 – 140 |
| Grinders | 106 – 110 |
| Chainsaws | 100 – 115 |
| Concrete saw | 97 – 103 |
| Sand blasting nozzle | 111 – 117 |
| Jackhammers | 100 – 115 |
| Compressors | 85 – 104 |

* Generally, newer equipment is quieter than older equipment. (For noise levels of specific equipment, contact the Construction Safety Association of Ontario.)

+ Pile drivers and explosive-actuated tools generate intermittent or "impulse" sound.

low. In this case HPD wearers with impaired hearing may have difficulty understanding speech because they must contend not only with their hearing loss but with the attenuation of their protector as well. In other cases, the use of HPDs by workers with normal hearing may actually *improve* their understanding of speech in noisy environments.

In other words, wearing HPDs doesn't always reduce the ability to communicate. Factors to consider include the user's hearing ability, noise levels, and the type of HPD. Where two-way communication is vital, radio-equipped hearing protectors can be worn (Figure 4).

Work Environment/Procedures

Choosing an HPD is sometimes dictated by the constraints of the work area or work procedures. For example, large volume earmuffs may not be practical in confined work situations with little head room or clearance.

In this case, flat-cup muffs or earplugs may be more practical. Where work is necessary near electrical hazards, it may be desirable to use non-conductive suspension-type muffs. The type of protector may also be determined by the nature of work, as in welding where certain types of earmuffs may interfere with the welder's helmet.

The attenuation of the muff-type hearing protector may be considerably reduced when worn with spectacle-type safety glasses. (The head configuration of the wearer and the type of glasses worn will determine the reduction in attenuation.) Where safety glasses must be worn, cable-type temples should be used in order to allow the smallest possible opening

Table 4

Effects of Hearing Protectors on Understanding Speech

| HEARING ABILITY OF WEARER | BACKGROUND / SURROUNDING NOISE LEVELS IN dBA | | |
|---------------------------|--|---------------|------------------------|
| | Less than 75 | 75 to 85 | Greater than 85 |
| Normal hearing | Little effect | No effect | Improves communication |
| Impaired hearing | Moderate effect | Little effect | No effect |

between the seal of the protector and the head. Otherwise earplugs should be worn, provided they are adequate.

Consideration should be given to hearing protectors which can be attached to hard hats where exposures to noise may be high but intermittent and where hard hats must be worn at all times. Periodic adjustments may be necessary because movement of the hard hat may break the seal of the HPD.

Consideration should also be given to work involving oils, grease, and other products which may soil hands. Ear infections may occur when earplugs are inserted by soiled hands.

Overprotection

Workers wearing HPDs that provide too much attenuation may feel isolated from their surroundings. Sounds may be heard as muffled. Speech or warning sounds may be unrecognizable. Overprotection can lead workers to resist wearing HPDs. Protectors should be chosen to provide sufficient, but not excessive, attenuation. The objective should be to reduce noise levels to or below the recommended maximum eight-hour exposure of 85 dBA, but not below 70 dBA.

Fit, Care, and Use

Workers should be instructed in the proper fitting of HPDs as recommended by the manufacturer. Training should include a demonstration. Workers should then practice using the HPDs under close supervision. Checks are needed to ensure the best possible protection. Many of these checks relate to fit.

Earmuffs

- 1) Earmuffs should conform to the latest issue of CSA Standard Z94.2.
- 2) The cup part of the earmuff should fit snugly over the entire ear and be held firmly in place by a tension band.
- 3) The cup and band should not be so tight as to cause discomfort.
- 4) Cup, cushion, and band should be checked for possible defects such as cracks, holes, or leaking seals before each use of the HPD.
- 5) Because band tension can be reduced over a period of time, the band may require repair or replacement.
- 6) Defective or damaged parts should be repaired or replaced as needed. Tension band, cushions, and cups are readily replaceable.

Earplugs

- 1) Earplugs should conform to the latest issue of CSA Standard Z94.2.
- 2) For maximum attenuation the method of insertion illustrated in Figure 5 should be used. Because the ear canal is slightly S-shaped, the ear must be pulled back to straighten the canal for the plug to fit properly.

Figure 5

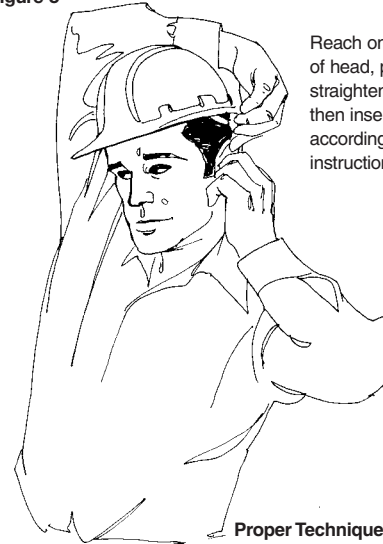

Reach one hand around back of head, pull ear upwards to straighten S-shaped ear canal, then insert plug with other hand according to manufacturer's instructions.

Proper Technique for Inserting Earplugs

- 3) Earplugs must be fitted snugly in the ear canal. This will cause some discomfort initially. However, in time (usually a period of two weeks) the discomfort vanishes. Should there be severe discomfort initially or mild discomfort for more than a few weeks, seek professional advice. In most instances it will only be a matter of re-sizing, although some ear canals cannot be fitted with plugs because of obstructions, unique shapes, or deformities. In fact, the shape of one ear canal may be entirely different from the other.
- 4) Reusable earplugs should be washed with warm soapy water daily to prevent the remote possibility of infection or other discomfort. When not in use, they should be kept in a clean container.
- 5) Earplugs with torn or otherwise damaged flanges should be replaced.

WARNING: Cotton batten does not provide adequate protection from construction noise.

Training

Workers who wear HPDs should be trained to fit, use, and maintain the protectors properly. Workers should understand

- that there is risk of hearing loss if HPDs are not worn in noisy environments (eight-hour exposure of 85 dBA)
- that wearing HPDs is required in all situations where noise exposure may damage hearing
- that to be effective an HPD must not be removed even for short periods
- that various HPDs are available to accommodate differences in ear canal size, jaw size, head size and shape, comfort level, compatibility with other forms of PPE, etc.
- that proper fit is essential to achieve maximum protection.

Audiometry

Anyone who works with noisy equipment on a regular basis should take a periodic audiometric or hearing capability test for the following reasons:

- 1) **To determine whether or not a hearing loss exists.** Even if no hearing loss is detected, workers exposed to noise levels in excess of 90 dBA should wear hearing protectors. Workers who have some hearing loss should wear HPDs to minimize any further loss.
- 2) **To determine the type of hearing loss.** Certain hearing losses can be reversed. Some individuals have suffered for years only to find out that their hearing problem could have been corrected surgically. These situations usually occur as a result of birth defects and are known as “conductive losses.”
- 3) **To determine the effectiveness of programs for noise control and hearing protection.** Early identification is important so that prevention practices can be implemented, maintained, and revised when necessary.

Summary

Control of noise in construction is of growing importance as a result of increasing hearing loss claims.

Most noise problems can be analyzed in terms of source, transmission path, and receiver. This allows a convenient understanding of the overall problem and a useful approach to remedial measures. The three components can usually be treated in isolation, although sometimes all three must be considered together in order to control unacceptable noise levels.

At source, remedial measures are aimed at reducing the noise being generated.

Along the transmission path, barriers can be introduced to reduce or eliminate noise reaching the ears.

For the receiver, remedial measures involve personal protective equipment properly selected, fitted, and worn. The equipment must be used in high noise environments **all the time**.

Failure to provide preventive or control measures will result in temporary and ultimately permanent hearing losses.

The Construction Safety Association of Ontario can assist management and labour in the industry by providing useful information, research, and training.

RESPIRATORY PROTECTION

Introduction

In the course of their work, construction personnel are often exposed to respiratory hazards in the form of dangerous dusts, gases, fumes, mists, and vapours.

In some cases careful selection of materials and work practices can virtually eliminate respiratory hazards. Where that is not possible, the next best choice is engineering controls such as fume exhaust systems that deal with the hazard at the source.

Respirators are the least preferred method of protection from respiratory hazards because they

- do not deal with the hazard at the source
- can be unreliable if not properly fitted and maintained
- may be uncomfortable to wear.

In spite of these drawbacks, in many construction operations respiratory protective equipment is the only practical control.

Respiratory Hazards

Respiratory hazards may be present as

- gases
- vapours
- fumes
- mist
- dusts.

Gases — consist of individual molecules of substances, and at room temperature and pressure, they are always in the gaseous state. Common toxic gases found in construction are carbon monoxide from engine exhaust and hydrogen sulphide produced by decaying matter found in sewers and other places.

Vapours — are similar to gases except that they are formed by the evaporation of liquids (e.g., water vapour). Common vapours found in construction are produced by solvents such as xylene, toluene, and mineral spirits used in paints, coatings, and degreasers.

Fumes — are quite different from gases or vapours, although the terms are often used interchangeably. Technically, fumes consist of small particles formed by the condensation of materials which have been subjected to high temperatures. Welding fume is the most common type of fume in construction. Other examples include pitch fume from coal tar used in built-up roofing and fume from diesel engines.

Mists — are small droplets of liquid suspended in air. The spraying of paint, form oils, and other materials generates mists of varying composition.

Dusts — are particles which are usually many times larger than fume particles. Dusts are generated by crushing, grinding, sanding, or cutting and by work such as demolition. Two kinds of hazardous dust common in construction are fibrous dust from insulation materials (such as asbestos, mineral wool, and glass fibre) and non-fibrous silica dust from sandblasting, concrete cutting, or rock drilling.

In construction settings, respiratory hazards may be compounded, depending on the number and variety of jobs under way. For example, both mist and vapours may be present from paint spraying or both gases and fumes from welding.

Health Effects

Respiratory hazards can be divided into the following classes based on the type of effects they cause.

Irritants are materials that irritate the eyes, nose, throat, or lungs. This group includes fibreglass dust, hydrogen chloride gas, ozone, and many solvent vapours. With some materials (e.g., cadmium fume produced by welding or oxyacetylene cutting of metals coated with cadmium) the irritation leads to a pneumonia-like condition called pulmonary edema. **This effect may not be apparent**

until several hours after exposure has stopped.

Asphyxiants are substances which result in inadequate oxygen in the body. They can be classified as either **simple asphyxiants** or **chemical asphyxiants**.

Simple asphyxiants are other gases or vapours which cause oxygen to be displaced, creating an **oxygen-deficient atmosphere**. Oxygen content of 18% may lead to some fatigue during exertion. Oxygen concentrations lower than 15% can cause loss of consciousness and may be fatal. For example, nitrogen used to purge tanks can displace oxygen, resulting in unconsciousness and even death for those who enter. Oxygen may also be consumed by chemical or biological activity such as rusting or bacteria digesting sewage.

Chemical asphyxiants interfere with the body's ability to transport or use oxygen. Two examples are carbon monoxide and hydrogen sulphide.

Central nervous system depressants interfere with nerve function and cause symptoms such as headache, drowsiness, nausea, and fatigue. Most solvents are central nervous system depressants.

Fibrotic materials cause "fibrosis" or scarring of lung tissue in the air sacs. Common fibrotic materials found in construction include asbestos and silica.

Carcinogens cause or promote cancer in specific body organs. Asbestos is the most common carcinogen in construction.

Nuisance dusts do not cause significant effects unless exposure is of high concentration and/or long duration. Excessive exposure to these substances can be adverse in itself or can aggravate existing conditions such as emphysema, asthma, or bronchitis. Examples include plaster dust, cellulose from some insulation, and limestone dust.

Respiratory Protective Equipment

A wide variety of equipment can be used to protect workers from respiratory hazards. Devices range from simple, inexpensive dust masks to sophisticated self-contained breathing apparatus. Generally, the equipment can be divided into two distinct classes — air-purifying respirators and supplied-air respirators.

Air-Purifying Respirators

As their name indicates, these devices purify the air drawn through them. There are two main types of air-purifying respirators:

1) Non-powered

Air is drawn through the air-purifying filter by the wearer breathing in and creating a negative pressure in the facepiece. Non-powered respirators depend entirely on the wearer breathing in (inhaling) and breathing out (exhaling) to deliver an adequate supply of purified breathing air.

2) Powered

These respirators have a blower that blows purified air into the facepiece. (Figure 6, page 61).

Air-purifying respirators have limitations and should not be used where

- there is insufficient oxygen
- very high concentrations of contaminant are present
- the contaminant cannot be detected by odour or taste at safe levels.

Warning: Air-purifying respirators simply remove certain airborne hazards. They do not increase or replenish the oxygen content of the air and should never be worn in atmospheres containing less than 19.5% oxygen.

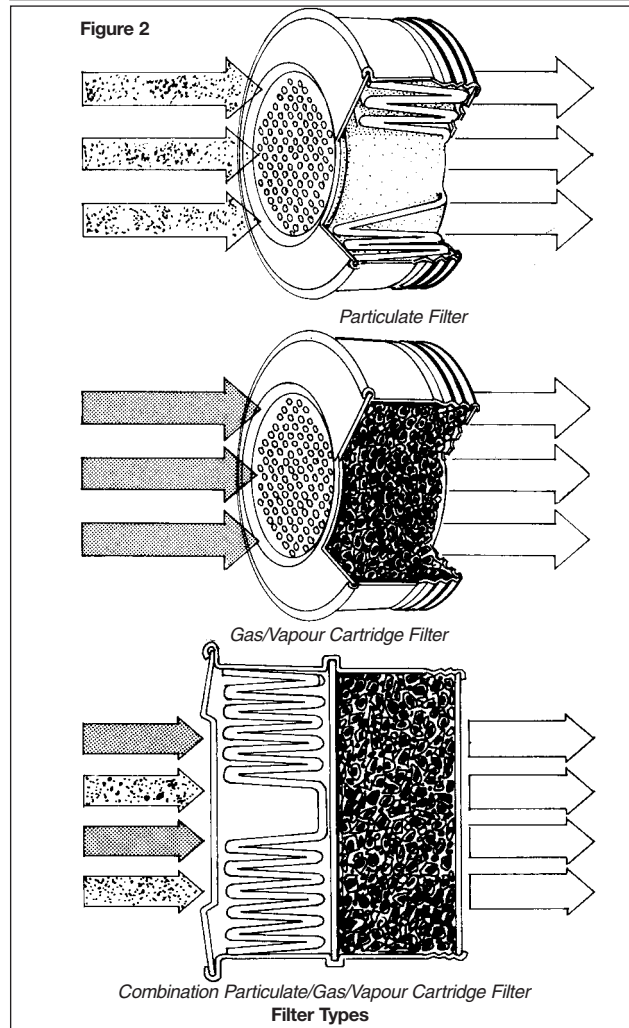

Although many different filters have been designed for specific hazards, there are three basic types used with air-purifying respirators:

- particulate filters
- gas/vapour cartridge filters
- combination particulate/gas/vapour filters. See Figure 2.

Particulate Filter

This type removes solid particles such as dusts, fumes, or mists and operates like the air filter in a car engine. The devices may be filtering facepiece respirators or respirators with replaceable filters. Different grades of filters are available, depending on the size of particles to be removed.

When particulate filters fill up with dust or fume, they become harder to breathe through but are more efficient, since air is being filtered through the layer of trapped particles as well as the filter itself.

While particulate filters can provide good protection against particles such as dusts, mists, or fumes, they cannot filter out gases or vapours because of the very small size of gas and vapour molecules.

Particulate filters for non-powered air-purifying respirators are divided into three levels of filter efficiency: 95%, 99%, and 99.97%. These numbers refer to the percentage of particles the filter can remove, based on the particle size most difficult to trap. Filters rated to these efficiencies outperform the dust/mist and dust/fume/mist filters of the past. For workers removing asbestos insulation or lead paint, for instance, the 99.97% efficiency cartridge would be the best choice. This is known as the 100 efficiency class, previously identified as the HEPA filter.

Oil has been found to ruin the filtering ability of some filter material. Oil coats the filter fibres, preventing the electrostatic charge on the fibres from attracting and removing particulates. Therefore, to ensure that a suitable filter is being used, particulate filters have an N, R, or P designation:

- N – Not resistant to oil
- R – Resistant to oil
- P – oil-Proof.

The N series of filters is suitable for airborne particles such as wood dust, when there are no oil-based particles also in the air. For example, an N series filter would be recommended during the removal of old lead paint. However, when spraying form oil or putting down hot asphalt—operations that involve airborne oil particles—the correct filter would have an R or P designation.

The R series—resistant to oil—should only be used for a single shift when solvent or oil mist is present in the air. This filter resists oil but may lose its filtering ability when in contact with oil over a long time.

When using P series filters, check the manufacturer's instructions to determine how long the filter can be used when airborne oil particles are present. P series filters were originally thought to be oil-proof but tests show there may be some loss of filtering ability with long-term oil exposure.

Warning: N, R, and P series filters by themselves do not provide protection against organic vapours.

Gas/Vapour Cartridge Filter

This type uses substances which absorb or neutralize gases and vapours. Unlike particulate filters, gas/vapour cartridge filters become less efficient the longer they are used. They act like sponges and, when full, allow gas or vapour to pass through without being absorbed. This is called “breakthrough.”

Common gas/vapour cartridge filters include the following:

- “Organic Vapour Cartridges” usually contain activated charcoal to remove vapours such as toluene, xylene, and mineral spirits found in paints, adhesives, and cleaners.
- “Acid Gas Cartridges” contain materials which absorb acids and may be used for protection against limited concentrations of hydrogen chloride, sulphur dioxide, and chlorine.
- “Ammonia Cartridges” contain an absorbent designed specifically to remove only ammonia gases.

Note

For respirators equipped with gas or vapour cartridges to be used safely, the contaminant must have good warning properties (odour, taste, or breathing irritation) that let the user know the cartridge is no longer working. When the user senses contaminant starting to penetrate the cartridge, it's time to change the cartridge.

When users depend on odour as a warning, the odour threshold of the contaminant must be below its exposure limit.

Certain cartridges are available with an end-of-service-life indicator. These cartridges have been developed for a few contaminants with poor warning properties such as carbon monoxide. The end-of-service-life indicator changes colour to warn the user to change the cartridge.

Cartridges must not be used for contaminants with poor warning properties unless the respirator manufacturer can offer cartridges with end-of-service-life indicators.

Combination Particulate/Gas/Vapour Cartridge with Filter

This type removes particulate matter, vapours, and gases from the air. It is used where more than one type of hazard is present or may develop.

Supplied-Air Respirators

Supplied-air respirators provide clean breathing air from an uncontaminated source, usually a special compressor located in a clean environment, or from cylinders containing compressed breathing air. The quality of the air supplied should meet the requirements of CSA Standard Z180.1, *Compressed Breathing Air and Systems*.

The moisture content of supplied air should be limited to prevent fogging, corrosion, and freezing of regulators and valves and to prolong the service life of filters used to remove other contaminants.

The “pressure dew point” is important in relation to moisture. The term refers to the temperature at which moisture in compressed air, at a given pressure, will condense out as droplets or “dew.” It must be kept at least 5°C below the lowest expected ambient temperature.

For example, if you are working where the temperature is -10°C, the dew point should be at least -15°C. Water vapour can be removed from compressed air with a drying system or water-absorbing materials.

Types of Supplied-Air Respirators

The three basic types of supplied-air respirators are airline unit, ambient air blower, and self-contained breathing apparatus (SCBA).

The **airline unit** depends on a hose connecting the respirator to cylinders of compressed breathing air. An abrasive-blasters hood is one example (Figure 3, page 61).

The **ambient air blower** draws air through an inlet hose (positioned where the air is clean) and pumps the air under fairly low pressure to the worker's hood, helmet, or facepiece.

The **self-contained breathing apparatus** (SCBA) uses a cylinder of air carried by the wearer (Figure 4). SCBAs are awkward, heavy, and require frequent cylinder changes.

Combination airline/SCBA units are available for work in confined spaces and other high-risk assignments where reserve protection is required (Figure 5).

With these devices or with simple airline units, the wearer's mobility is understandably restricted by the trailing hose and the length of line available. In addition, airlines may get crimped or may snag on equipment.

If an atmosphere is immediately dangerous to life or health, a combination airline/SCBA unit is required.

Both airline and SCBA units are more expensive than air-purifying systems, but they generally provide much greater protection.

Modes of Operation

Respirators can operate in the following modes:

- “negative pressure” or “demand”
- “constant-flow”
- “positive pressure” or “pressure-demand.”

Negative Pressure or Demand Mode

Air is delivered only when the wearer inhales. Pressure inside the facepiece is then lower than pressure outside the facepiece. This allows air to pass through the filters in the case of air-purifying respirators, or actuates a valve that allows air into the facepiece in the case of supplied-air respirators. Because contaminated air may leak inward around the facepiece, these devices have limited use in high exposure conditions.

Constant-Flow Mode

As the name implies, these devices deliver a constant flow of air to the wearer. Powered air-purifying respirators (PAPRs) use a battery-powered fan to draw air through the filter and then blow it into the facepiece (Figure 6). Constant-flow supplied-air respirators such as sandblasters' hoods use a simple valve to control the flow of “clean” air from the compressor. Minimum flow rates of 170 litres per minute (6 cubic ft/min) for loose-fitting hoods or helmets and 115 litres per minute (4 cubic ft/min) for tight-fitting facepieces must be maintained to minimize inward leakage of contaminated air and still provide adequate breathing air.

Positive Pressure or Pressure-Demand Mode

Since the previous modes may permit significant inward leakage, a system which maintains a positive pressure inside the facepiece at all times, as well as supplying more air as demanded, was developed.

If leakage occurs, the high pressure inside the facepiece directs the leakage away from the facepiece rather than allowing it in.

This class of device is only available with supplied-air respirators.

Styles of Facepieces

In addition to the type of respirator and mode of operation, the style of facepiece is used to classify respirators. Different styles are available (Figure 7).

Protection Factors

The protection factor (PF) is a measure of the effectiveness of a respirator. PFs are determined by dividing the concentration of a contaminant outside the respirator by the concentration inside the respirator. PFs are used in the selection process to determine the maximum use concentration (MUC) for the respirator. The MUC is determined by multiplying the legislated or recommended exposure limit by the PF.

For example, the exposure limit for chrysotile asbestos in Ontario is 0.1 fibre/cm³ of air. If we are using a half-mask respirator with N100 filters (PF=10), the MUC is 1 fibre/cm³. This is obtained by multiplying the PF (10) by the exposure limit (0.1 fibre/cm³). If the concentration of asbestos becomes greater than 1 fibre/cm³ during the course of work, a respirator with a greater protection factor must be used.

The Canadian Standards Association (CSA), the US National Institute for Occupational Safety and Health (NIOSH), and the American National Standards Institute (ANSI) have each published slightly different protection factors. In this manual, NIOSH-assigned protection factors are used.

The degree of protection depends on the type of respirator, style of facepiece, and principle of operation.

Generally, supplied-air respirators provide better protection than air-purifying respirators; full-face masks provide better protection than half-face masks; and positive-pressure devices provide more protection than negative-pressure types.

Table 1 on page 63 lists protection factors for the respirators described so far. The information can be used to select the most appropriate device for any given situation.

The protection factors listed in Table 1 were determined by testing a wide variety of devices worn by a large number of people and represent the average degree of protection achieved. Protection factors for individual wearers may differ significantly from the values listed.

Respirator Selection

In order to select the proper respirator for a particular job, it is necessary to know and understand

- the characteristics of the contaminant(s)
- the anticipated exposure conditions
- the performance limitations of the equipment
- any legislation that applies.

It is also important to realize that facial hair and deep facial scars can interfere with the seal between respirator and face. Respirators should only be selected by someone who understands all of these factors.

Before using or handling a controlled product, consult the material safety data sheet (MSDS). The MSDS will identify any respiratory protection required. Under the Workplace Hazardous Materials Information System (WHMIS), MSDSs

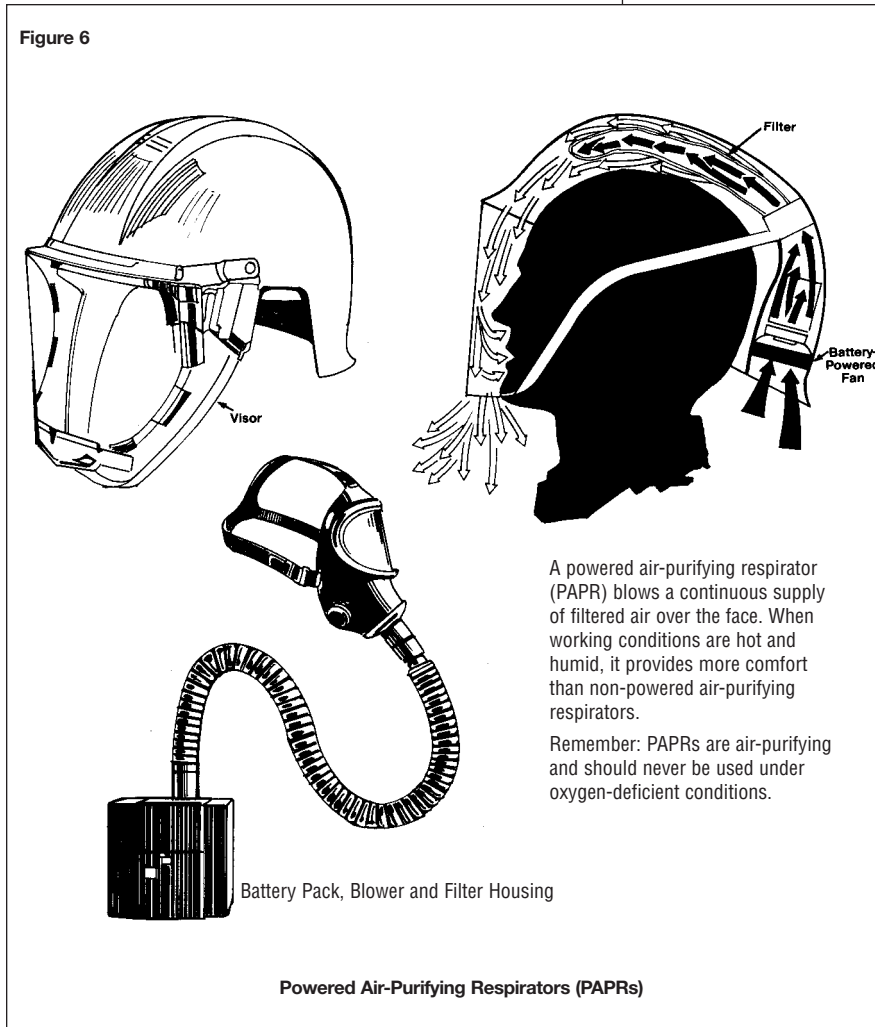
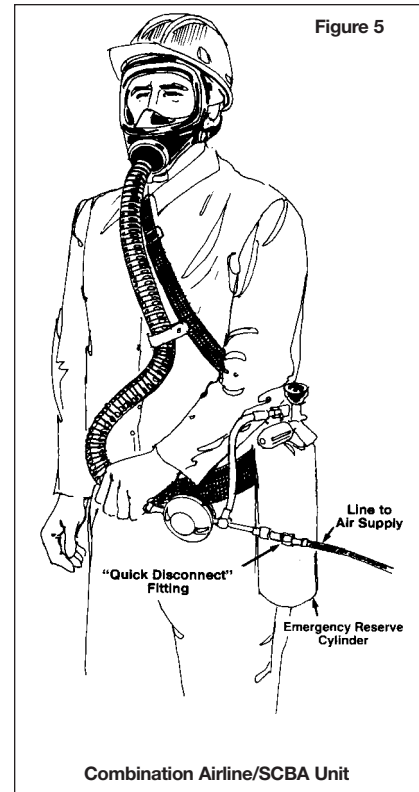
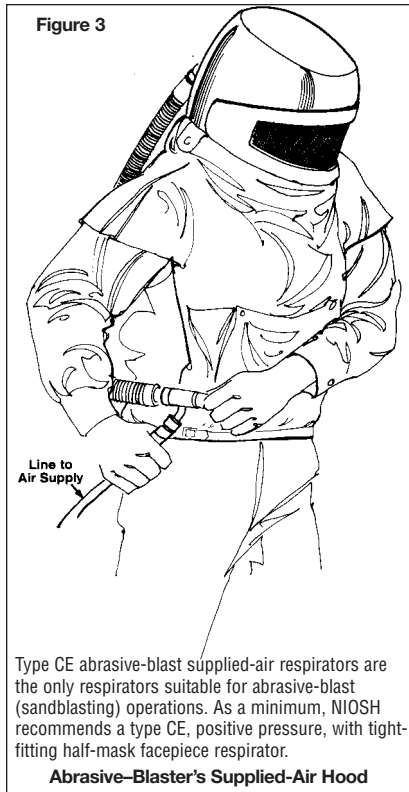

must be available to users of controlled products. The MSDS should specify the type of respirator to be worn.

The chart on pages 67-73 is a guide to respirator selection. It is intended as a guide only and may not be applicable to every case.

For activities not listed, information regarding type of work, nature of material(s) involved, and working conditions is required and expert advice should be obtained.

If there is any doubt about the correct type of protection for a specific material and operation, consult the manufacturer of the product, a supplier or manufacturer of respirators, or CSAO. When seeking information on the type of respirator for use in specific situations, provide as much of the following information as possible:

- Name and form of the material (oil or non-oil). If the form is unknown, consider it an oil.
- Type of work to be done (e.g., painting, welding).
- Description of worksite conditions (e.g., inside a tank, outdoors).
- Exposure concentration, if known (e.g., 150 ppm of toluene).
- Whether the material will be heated, sprayed, etc.

Figure 7

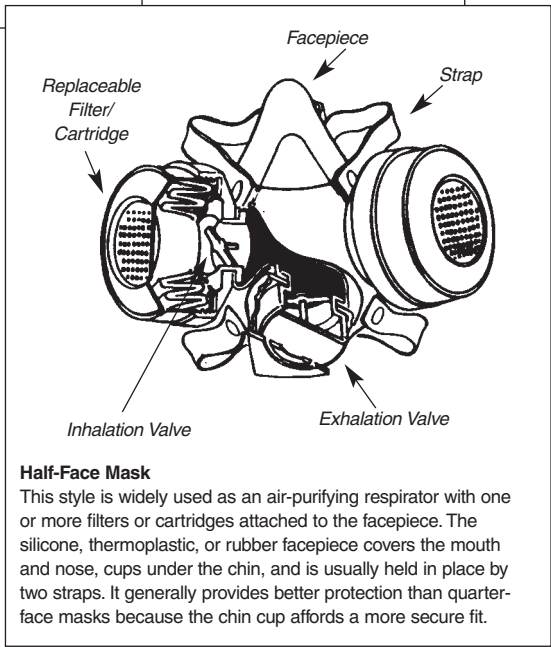
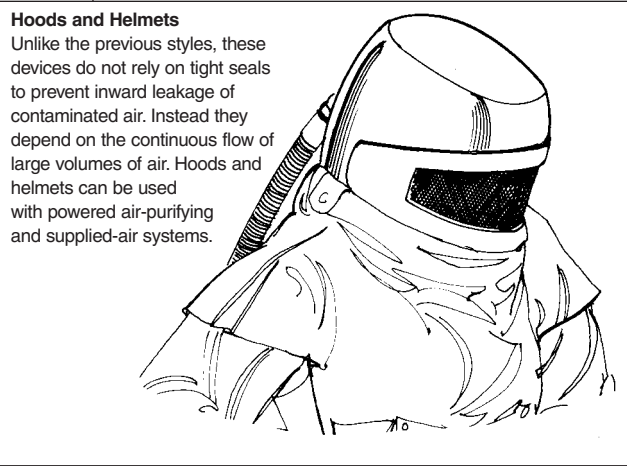
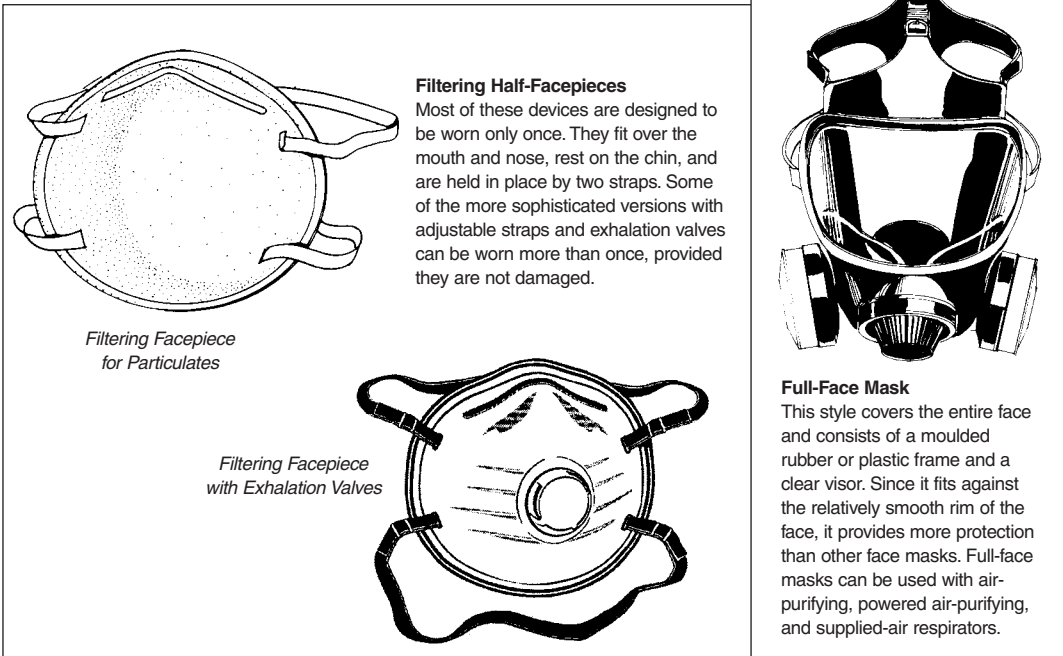

f) Other materials being used in the vicinity.

The respiratory protection specialist will evaluate this information and compare it with the following additional data:

- g) The permissible exposure limit of the dust, gas, or vapour, often referred to as the TLV® or Threshold Limit Value*. These values are used in conjunction with the protection factors listed in Table 1 to determine the maximum use concentration.
- h) The physical properties of the contaminant:
 - Vapour Pressure — The maximum amount of vapour which can be generated under given conditions.

- Warning Properties (e.g., irritation, odour, taste) — If the material has poor warning properties (for example, when the lowest concentration that can be detected by odour is greater than the permissible exposure concentration), air-purifying respirators are usually not permitted.
- Types of Effects — With cancer-causing materials a higher degree of protection is usually specified.
- Performance of Filters — With some gases and vapours the filter can become overloaded in just a few minutes. Therefore, knowledge of the filtering material and its performance against specific gases and vapours is necessary.
- i) The concentration considered to be Immediately Dangerous to Life or Health (IDLH). IDLH atmospheres pose an immediate threat to life or

*TLV is a term copyrighted by the American Conference of Governmental Industrial Hygienists.

Table 1: Protection Factors (according to NIOSH)

| Type of Respirator | Facepiece Style | Facepiece Pressure | Cartridge Type | Hazard Form | Protection Factor |
|-----------------------|--------------------------|--------------------|----------------|-----------------------|-------------------|
| Air-purifying | Filtering Half-Facepiece | N | N/A | Particle | 10 ‡ |
| | Half-face mask | N | 1 | Particle, gas, vapour | 10 ‡ |
| | Full-face mask | N | 1 | Particle | 10 |
| | Full-face mask | N | 2 | Particle | 50 |
| | Full-face mask | N | 3 | Gas, vapour | 50 ‡ |
| Powered air-purifying | Loose hood helmet | C | 1 | Particle, gas, vapour | 25 ‡ |
| | Tight-fitting facepiece | C | 3 | Gas, vapour | 50 ‡ |
| | Tight-fitting facepiece | C | 2 | Particle | 50 |
| Airline | Half-face mask | N | N/A | Particle, gas, vapour | 10 |
| | Half-face mask | P | N/A | Particle, gas, vapour | 1,000 |
| | Full-face mask | N | N/A | Particle, gas, vapour | 50 |
| | Full-face mask | P | N/A | Particle, gas, vapour | 2,000 |
| | Hood or helmet | C | N/A | Particle, gas, vapour | 25 |
| SCBA * | Half-face mask | P | N/A | Particle, gas, vapour | 1,000 |
| SCBA * | Full-face mask | N | N/A | Particle, gas, vapour | 50 |
| SCBA * | Full-face mask | P | N/A | Particle, gas, vapour | 10,000 |

* SCBA or airline with emergency air bottle adequate for escape from the hazardous environment
 ‡ Protection factor may be limited by the cartridge. Check with manufacturer.

N Negative
 C Constant flow
 P Positive
 N/A Not applicable
 1 Any appropriate NIOSH-approved
 2 High efficiency particulate aerosol (HEPA)
 3 Appropriate NIOSH-approved gas or vapour

health or the threat of a serious but delayed effect on health (e.g., radioactive dust exposures). One example of an IDLH situation is the repair of a chlorine leak where a worker could be overcome by the gas very quickly. IDLH atmospheres should only be entered by persons wearing SCBA or SCBA/airline respirators as shown in Figures 4 and 5.

- j) Possibility of skin absorption. With some chemicals the amount of material which can be absorbed through the skin is of equal or greater concern than the amount of gas or vapour which can be inhaled. For these situations supplied-air protective suits may be necessary.
- k) Eye irritation — some contaminants will cause eye irritation, making it difficult to see. For these contaminants, a full-face mask must be worn.

As shown by points a) to k), many factors must be considered to ensure that the proper respirator is selected for a specific situation.

Note
 Facial hair and eye protection can adversely affect the respirator seal. Facial hair between the face and a tight-fitting respirator can cause a great deal of leakage and reduce the effectiveness of protection significantly. Respirator wearers should be clean-shaven to achieve the best possible seal. Where eye protection with temple bars or straps passing between face and respirator is necessary, consider wearing a full-face mask.

Fit Testing

Once a respirator has been selected, the next critical step is ensuring that it fits properly. One size does not fit all.

With every respirator except hoods or helmets, a tight seal is required between facepiece and face.

With negative-pressure respirators (e.g., non-powered air-purifying respirators and demand supplied-air respirators) gaps in the seal will permit contaminated air to enter the breathing zone.

With positive-pressure respirators (e.g., powered air-purifying respirators and pressure-demand supplied-air respirators) a lot of air will be wasted through outward leakage and the degree of protection provided to the wearer could be reduced. Also, “venturi effects” may allow air to escape in one area and draw contaminated air into the facepiece around the escaping air.

For these and other reasons, the fit of respirators must be carefully tested. Generally there are two types of fit testing – qualitative and quantitative.

Qualitative Fit Tests

- 1) **Irritant Smoke Test** — The wearer puts on the respirator with “high efficiency or fume filters” in place. A cloud of irritant smoke is created around the wearer. If leakage is detected the respirator should be adjusted.

Caution: Most of the smoke clouds used in this test are very irritating to the eyes, nose, and throat. Workers are advised to keep their eyes closed during the test and to back out of the smoke as soon as they notice any leakage or irritation.

- 2) **Iso Amyl Acetate (Banana Oil) Test** — The wearer puts on the respirator with “organic vapour” cartridge filters in place. A cotton swab dipped in iso amyl acetate solution is passed along the outline of the facepiece (iso amyl acetate smells like very ripe



bananas). If the wearer smells the solution, the respirator should be adjusted.

Note: Some people cannot smell iso amyl acetate. Before starting the test, check to ensure that the person can detect the odour. Use two small jars, one containing water, the other containing the test solution. Ask the person whether one smells different and what it smells like.

- 3) **Saccharin Test** — This test is similar to the iso amyl acetate test except that it uses saccharin as the test material and a dust/mist or high efficiency respirator. If the sweet taste or smell of saccharin is detected, the fit must be adjusted.
- 4) **Bitrex Solution Aerosol Test** — In this test the wearer puts on the respirator with any particulate filter. A hood or test enclosure is put over the wearer's head and shoulders. Bitrex is then sprayed into the hood or enclosure. Bitrex is a very bitter solution and can easily be detected if it leaks through the face seal. If the wearer cannot taste the Bitrex, then the respirator fits properly.

Quantitative Fit Tests

In these tests the wearer puts on a special respirator which has a probe mounted inside the facepiece. The wearer then goes into a test chamber or booth which contains a known concentration of a specific gas, vapour, or aerosol. The amount of leakage is determined by sampling the air inside the facepiece through the probe. This method is not well suited for use on most construction projects.

User Seal Checks

- 1) **Negative Pressure Test** — The wearer puts on the respirator and adjusts it so that it feels relatively comfortable. Then the air inlets are blocked off with the hands or a plastic cover, and the wearer inhales gently (Figure 7). If the respirator is properly fitted, it should collapse slightly and not permit any air into the facepiece. If leakage is detected, the mask should be readjusted and the test repeated until the fit is satisfactory.
- 2) **Positive Pressure Test** — The wearer puts on the respirator and adjusts it so that it feels relatively comfortable. Then the exhaust port of the respirator is covered and the wearer tries to exhale gently (Figure 8). The facepiece should puff away from the wearer, but no leakage should occur.

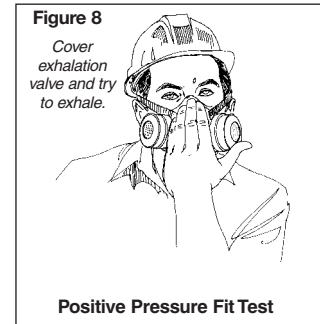
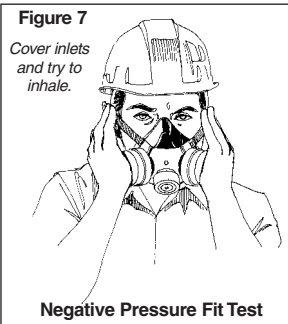

Respirator Maintenance

Like any equipment, respirators require maintenance. The following instructions cover the major points.

- 1) Filters should be changed as follows:
 - Dust/mist/fume filters should be changed when there is noticeable resistance to normal breathing.
 - Chemical cartridge respirators should be changed when the gas or vapour can be tasted or smelled.
 - Any filter should be changed at the interval specified by the manufacturer or when damaged in any way.
- 2) Inhalation and exhalation valves should be checked before the respirator is used.
- 3) Damaged facepiece, straps, filters, valves, or other parts should be replaced with “original equipment” parts.
- 4) Facepieces should be washed with mild soapy water as often as necessary to keep them clean and wearable.
- 5) Respirators should be assigned to the exclusive use of individual workers.
- 6) Where a respirator must be assigned to more than one worker, it should be disinfected after each use (check with the manufacturer regarding acceptable sanitizers/disinfectants).
- 7) Check all supply hoses, valves, and regulators on supplied-air respirators as specified by the manufacturer.
- 8) SCBA units and high-pressure cylinders of compressed breathing air should be used and maintained in accordance with current Canadian Standards Association Z180.1 *Compressed Breathing Air and Systems*, and Z94.4 *Selection, Care and Use of Respirators*.
- 9) Compressors and filtration systems used with supplied-air respirators must be maintained in accordance with the manufacturers’ recommendations.
- 10) Consult manufacturer for information on respirator cartridge change-out.

Approvals and Standards

The most commonly referenced standards for respiratory protection in North America are the test criteria used by the National Institute for Occupational Safety and Health (NIOSH).

NIOSH is a U.S. government agency which tests and approves respiratory protective equipment as one of its major activities and publishes a list of approved devices annually.

The Construction Safety Association of Ontario recommends that only NIOSH-approved equipment be used for protection against respiratory hazards. Unapproved devices should be evaluated carefully by a competent respiratory protection specialist before use.

The Canadian Standards Association has issued two standards pertaining to respiratory protection which should be reviewed by the person responsible for the respirator program:

- Z180.1 *Compressed Breathing Air and Systems* lists the criteria for air purity and delivery systems
- Z94.4 *Selection, Care and Use of Respirators* offers recommendations on these three aspects of the subject.

These standards are copyrighted by CSA. Copies can be purchased from

Canadian Standards Association
 178 Rexdale Boulevard
 Rexdale, Ontario
 M9W 1R3
 (416) 747-4000 www.csa.ca

Review

The following section lists common claims about respirators and explains why the statements are true or false. The information provides a convenient review of major points in this chapter.

- | | | |
|--|---------|---|
| 1) All respirators are the same. | (False) | Most respirators, especially air-purifying types, are limited to certain types of hazards. For instance, dust masks may be suitable for dusts, but do not provide protection against gases and vapours. |
| 2) One size fits all. | (False) | Most manufacturers offer three sizes of facepieces (small, medium and large) to ensure a proper fit. In some cases, no size from one manufacturer may fit an individual and a different brand may be necessary. |
| 3) Respirators make breathing more difficult | (True) | With air-purifying respirators the air is being inhaled through a filter so some additional effort is required. With most pressure/demand supplied-air respirators additional effort is required to activate the inhalation and exhalation valves. |
| 4) Air-purifying respirators supply oxygen. | (False) | These devices simply filter out specific gases, vapours, dust, mists, or fumes, but do not increase the oxygen content of the air. |





- | | | |
|---|---------|---|
| 5) Most respirators require maintenance. | (True) | With the exception of disposable and single-use respirators, some maintenance is required. |
| 6) Any source of compressed air will be adequate for supplied-air respirators. | (False) | Compressed breathing air must be “clean” and free from carbon monoxide, oil mist, and other contaminants. |
| 7) Protection factors are the same for everyone. | (False) | The protection factors listed in Table 1 (page 63) are averages obtained by testing a large number of wearers. Individual protection factors can be considerably different from those listed. |
| 8) Respirators are the best way to control respiratory hazards. | (False) | Good ventilation is the best way of controlling respiratory hazards, though it is not always practical in many construction applications. |
| 9) The moisture content of compressed air is important. | (True) | If the moisture content of the air in a pressurized breathing air system is too high, the regulators can freeze shut and cut off the supply of air. Moisture can also cause deterioration of storage cylinders. |
| 10) Parts can be interchanged from one manufacturer to another. | (False) | Using improperly fitted or matched components voids the NIOSH approval and can cause failure of the respirator posing serious risk to the wearer. |
| 11) Fitting of respirators is not important. | (False) | No matter how effective its protection against specific hazards, the respirator must be properly fitted to prevent inward leakage of contaminated air. The only exceptions are hoods and helmets, and even these depend on fit to a certain degree. |
| 12) Self-Contained Breathing Apparatus (SCBA) and air-line respirators provide the best protection. | (True) | They also have disadvantages which make their use impractical in some situations (see pages 59-60). |
| 13) Respirators should be checked each time they are used. | (True) | Damaged straps, missing or ill-fitting valves, and other problems can make the device useless. |
| 14) Only one respiratory hazard is present in a particular job. | (False) | Often there are two or more hazards present. For instance, spray painting produces mists and vapours while welding can produce fume and gases. |
| 15) Respirators can be fitted with filters suitable for more than one hazard. | (True) | Many manufacturers offer filters which will remove selected dusts, fumes, gases, and vapours all at the same time. |
| 16) Single-use dust masks should not be worn more than once. | (True) | These inexpensive respirators are meant to be put on once only. They may not provide adequate protection once the straps have been stretched. |
| 17) Respirators provide absolute protection. | (False) | Every respirator has limitations which the wearer must understand. Protection is ensured not only by the respirator but also by its proper use. |
| 18) Respirators are simple to select for any job. | (False) | In many cases even the respiratory protection specialists have problems in selecting the right device. |
| 19) Respirators interfere with eye protection. | (True) | Protective goggles and glasses may not fit properly with many respirators. Full-face masks may be necessary. |
| 20) NIOSH approvals are important. | (True) | NIOSH approvals indicate that the device has passed a set of minimum design and performance standards. Unapproved respirators may provide similar protection but this can only be evaluated by expert review of the manufacturer’s claims. |
| 21) Beards and mustaches do not affect respiratory protection. | (False) | With the exception of hoods and some helmets, beards and mustaches cause a great deal of leakage and reduce the effectiveness of respirators significantly. Respirator wearers should be clean shaven to obtain the best possible protection. |

Summary

Respiratory protective equipment can prevent illness, disease, and death from breathing hazards. But the equipment must be properly selected, fitted, worn, and maintained to ensure maximum protection.

The Construction Safety Association of Ontario can provide assistance in selecting respiratory protection and training workers in its use, care, and maintenance. For additional information, contact CSAO.

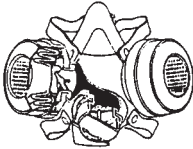
Respirator Selection Guide for Common Construction Activities

| Air purifying | | | | | | | | | | | Supplied air | | |
|---|--|--|---|--|--|---|--|--|--|--|---|----------------|--|
| Half facepiece | | | | | | Full facepiece | | | | | Powered Air-Purifying Respirator (PAPR), tight-fitting | Hood or Helmet | SCBA or SCBA + airline, full facepiece and positive pressure |
| Filtering facepiece | | | Elastomeric facepiece | | |  | | | | | | | |
|  | | |  | | | | | | | |  | | |

| | | | | | | | | | | | | | |
|--|----|-----|----|-----|----------------|--------------------|---------------------|----|-----|---------------------|------|------|--------|
| Filter efficiency and type | 95 | 100 | 95 | 100 | Organic vapour | 95+ organic vapour | 100+ organic vapour | 95 | 100 | 100+ organic vapour | HEPA | | |
| Assigned Protection Factor* (NIOSH 1987) | 10 | 10 | 10 | 10 | 10 | 10 | 10 | 10 | 50 | 50 | 50 | 1000 | 10,000 |

Asbestos: see page 209.

| Lead | | | | | | | | | | | | | |
|---|--|--|-----------------------------|--|--|--|--|--|--|--|-----------------------------------|--|--|
| Application of lead-containing coatings with a brush or roller | | | Optional ✓ N, R, or P | | | | | | | | | | |
| Spray application of lead-containing coatings | | | | | | | | | | | ✓ Loose-fitting hood or helmet | | |
| Removal of lead-containing coatings or materials by scraping or sanding using non-powered hand tools | | | ✓ N, R, or P | | | | | | | | | | |
| Removal of lead-containing coatings or materials using non-powered hand tools—other than manual scraping or sanding | | | Optional ✓ N, R, or P | | | | | | | | | | |
| Removal of lead-containing coatings with a chemical gel or paste and fibrous laminated cloth wrap | | | Optional ✓ N, R, or P | | | | | | | | | | |
| Removal of lead-containing coatings or materials using a power tool <i>without</i> a dust collection system equipped with a HEPA filter (airborne dust ≥ 0.05 mg/m ³) | | | | | | | | | | | ✓ Full facepiece | | |

Continued on next page . . .



N = Not resistant to oil R = Oil-resistant P = Oil-proof OV = Organic vapour cartridge

✓ indicates suitable protection. If oil mist is present, use R or P filters.

* Assigned protection factor: The protection factor assigned by NIOSH, the US National Institute for Occupational Safety and Health. It's a measure of the effectiveness of a type of respirator and suitable filter. Higher numbers mean greater protection. You may use a respirator with a greater protection factor than the one recommended for your task. Never use a respirator with a smaller protection factor.

These recommendations will provide adequate protection in most circumstances. Factors such as ventilation, duration of exposure, and user characteristics can affect how well a respirator protects you. If unsure about the respirator required for a task, contact the manufacturer or CSAO at 1-800-781-2726, www.csa.org.

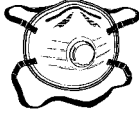
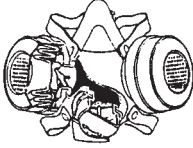
Respirator Selection Guide for Common Construction Activities

| Air purifying | | | | | | | | | | | Supplied air | | |
|---|--|--|---|--|--|---|--|--|--|--|---|----------------|--|
| Half facepiece | | | | | | Full facepiece | | | | | Powered Air-Purifying Respirator (PAPR), tight-fitting | Hood or Helmet | SCBA or SCBA + airline, full facepiece and positive pressure |
| Filtering facepiece | | | Elastomeric facepiece | | |  | | | | | | | |
|  | | |  | | | | | | | |  | | |

| | | | | | | | | | | | | | |
|--|----|-----|----|-----|----------------|--------------------|---------------------|----|-----|---------------------|------|------|--------|
| Filter efficiency and type | 95 | 100 | 95 | 100 | Organic vapour | 95+ organic vapour | 100+ organic vapour | 95 | 100 | 100+ organic vapour | HEPA | | |
| Assigned Protection Factor* (NIOSH 1987) | 10 | 10 | 10 | 10 | 10 | 10 | 10 | 10 | 50 | 50 | 50 | 1000 | 10,000 |

| Lead cont'd | | | | | | | | | | | | | |
|--|--|--|-----------------------------|--|--|--|--|--|--|--|-----------------------------------|--|--|
| Removal of lead-containing coatings or materials using a power tool with a dust collection system equipped with a HEPA filter (airborne dust must be controlled to < 0.05 mg/m ³) | | | Optional ✓ N, R, or P | | | | | | | | | | |
| Abrasive blasting of lead-containing coatings or materials | | | | | | | | | | | | ✓ Type CE blasting; positive pressure; tight-fitting half-facepiece | |
| Dry removal of lead-containing mortar using an electric or pneumatic cutting device | | | | | | | | | | | ✓ Tight-fitting full facepiece | | |
| Welding or high-temperature cutting of lead-containing coatings or materials indoors or in a confined space | | | | | | | | | | | ✓ Tight-fitting full facepiece | | |
| Welding or high-temperature cutting of lead-containing coatings or materials outdoors—long-term operations or if material not pre-stripped | | | | | | | | | | | ✓ Tight-fitting full facepiece | | |
| Welding or high-temperature cutting of previously stripped lead-containing coatings or materials outdoors—short term only | | | ✓ N, R, or P | | | | | | | | | | |
| Burning of a surface containing lead | | | | | | | | | | | ✓ Tight-fitting full facepiece | | |
| Soldering | | | Optional ✓ N, R, or P | | | | | | | | | | |
| Installation or removal of lead-containing sheet metal | | | Optional ✓ N, R, or P | | | | | | | | | | |
| Installation or removal of lead-containing packing, babbitt, or similar material | | | Optional ✓ N, R, or P | | | | | | | | | | |

Continued on next page . . .

N = Not resistant to oil R = Oil-resistant P = Oil-proof OV = Organic vapour cartridge

Respirator Selection Guide for Common Construction Activities

| Air purifying | | | | | | | | | | | Supplied air | | |
|---------------------|--|--|-----------------------|--|--|---|--|--|--|--|--|----------------|--|
| Half facepiece | | | | | | Full facepiece | | | | | Powered Air-Purifying Respirator (PAPR), tight-fitting | Hood or Helmet | SCBA or SCBA + airline, full facepiece and positive pressure |
| Filtering facepiece | | | Elastomeric facepiece | | |  | | | | | | | |

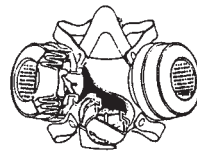
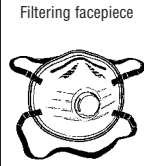

| | | | | | | | | | | | | | |
|--|----|-----|----|-----|----------------|--------------------|---------------------|----|-----|---------------------|------|------|--------|
| Filter efficiency and type | 95 | 100 | 95 | 100 | Organic vapour | 95+ organic vapour | 100+ organic vapour | 95 | 100 | 100+ organic vapour | HEPA | | |
| Assigned Protection Factor* (NIOSH 1987) | 10 | 10 | 10 | 10 | 10 | 10 | 10 | 10 | 50 | 50 | 50 | 1000 | 10,000 |

| Lead cont'd | | | | | | | | | | | | | | |
|---|--|-----------------|--|--|--|--|--|--|--|--|--|--|--------------------------------------|--|
| Demolition or cleanup of a facility where lead-containing products were manufactured | | | | | | | | | | | | | ✓ Tight-fitting full facepiece | |
| Manual demolition of lead-painted plaster walls or building components using a sledgehammer or similar tool | | ✓ N, R, or P | | | | | | | | | | | | |
| Removal of lead-containing dust using an air-mist extraction system | | | | | | | | | | | | | ✓ Pressure demand; full facepiece | |
| Removal or repair of a ventilation system used for controlling lead exposure | | | | | | | | | | | | | ✓ Tight-fitting full facepiece | |
| An operation that may expose a worker to lead dust, fume, or mist, that is not a Type 1, Type 2, or Type 3b operation | | | | | | | | | | | | | ✓ Tight-fitting full facepiece | |

| Painting | | | | | | | | | | | | | | |
|--|-------------------------------|--|-------------------------------|--|--|-------------|-------------|--|--|--|--|-----------------|-------------|---|
| Spraying latex paint | ✓ N, R, or P (small-scale) | | ✓ N, R, or P (small-scale) | | | | | | | | | | | |
| Alkyds, enamels, and sealers: brush and roller application indoors but well-ventilated | | | | | | ✓ R or P | | | | | | | | |
| Alkyds and enamels: spray painting in well-ventilated area | | | | | | | | | | | | | ✓ R or P | |
| Alkyds and enamels: painting in a confined space | | | | | | | | | | | | | | ✓ |
| Epoxy or polyurethane spray painting | | | | | | | | | | | | | ✓ | |
| Spraying lead paint | | | | | | | | | | | | ✓ N, R, or P | ✓ | |
| Spraying stucco | | | | | | | ✓ R or P | | | | | | | |

N = Not resistant to oil R = Oil-resistant P = Oil-proof OV = Organic vapour cartridge

Respirator Selection Guide for Common Construction Activities

| Air purifying | | | | | | | | | | | Supplied air | | |
|---------------------|--|-----------------------|--|--|---|--|--|--|--|--|--|----------------|--|
| Half facepiece | | | | | Full facepiece | | | | | | Powered Air-Purifying Respirator (PAPR), tight-fitting | Hood or Helmet | SCBA or SCBA + airline, full facepiece and positive pressure |
| Filtering facepiece | | Elastomeric facepiece | | |  | | | | | | | | |

| | | | | | | | | | | | | | |
|--|----|-----|----|-----|----------------|--------------------|---------------------|----|-----|---------------------|------|------|--------|
| Filter efficiency and type | 95 | 100 | 95 | 100 | Organic vapour | 95+ organic vapour | 100+ organic vapour | 95 | 100 | 100+ organic vapour | HEPA | | |
| Assigned Protection Factor* (NIOSH 1987) | 10 | 10 | 10 | 10 | 10 | 10 | 10 | 10 | 50 | 50 | 50 | 1000 | 10,000 |

| Roofing | | | | | | | | | | | | | |
|---|-----------------|--|-----------------|--|-----------------|--|--|--|-------------|-----------------|----------|--|--|
| Removal of roofing material (built-up roofing, no asbestos) | ✓ R or P | | ✓ R or P | | | | | | ✓ R or P | | | | |
| Heat welding roofing membrane | ✓ N, R, or P | | ✓ N, R, or P | | | | | | | | | | |
| Adhesive welding roofing membrane | | | | | ✓ N, R, or P | | | | | | | | |
| Roofing kettle operators (asphalt) | | | | | | | | | | ✓ N, R, or P | ✓ +OV | | |

| Silica | | | | | | | | | | | | | |
|--|-----------------|--|-----------------|-----------------|--|--|--|--|--|--|--|---|--|
| Breaking concrete outdoors | ✓ N, R, or P | | ✓ N, R, or P | | | | | | | | | | |
| Crushing rock and gravel | | | ✓ N, R, or P | ✓ N, R, or P | | | | | | | | | |
| Blasting rock | | | ✓ N, R, or P | ✓ N, R, or P | | | | | | | | | |
| Abrasive blasting—either ≥ 1% silica in the abrasive blasting media or ≥ 1% silica in the target material being blasted | | | | | | | | | | | | ✓ | |
| Drywall sanding | | For short-term applications, a filtering facepiece respirator may be appropriate | ✓ N, R, or P | ✓ N, R, or P | | | | | | | | | |
| Machine mixing concrete or mortar | | | ✓ N, R, or P | ✓ N, R, or P | | | | | | | | | |
| Drilling holes in concrete or rock that is not part of a tunnelling operation or road construction | | | ✓ N, R, or P | ✓ N, R, or P | | | | | | | | | |
| Milling of asphalt from concrete highway pavement | | | ✓ N, R, or P | ✓ N, R, or P | | | | | | | | | |
| Charging mixers and hoppers with silica sand (sand consisting of at least 95% silica) or silica flour (finely ground sand consisting of at least 95% silica) | | | ✓ N, R, or P | ✓ N, R, or P | | | | | | | | | |
| Any other operation at a project that requires the handling of silica-containing material in a way that a worker may be exposed to airborne silica | | | ✓ N, R, or P | ✓ N, R, or P | | | | | | | | | |

Continued on next page . . .

N = Not resistant to oil R = Oil-resistant P = Oil-proof OV = Organic vapour cartridge

Respirator Selection Guide for Common Construction Activities

| Air purifying | | | | | | | | | | | Supplied air | | |
|---------------------|--|--|-----------------------|--|--|---|--|--|--|--|--|----------------|--|
| Half facepiece | | | | | | Full facepiece | | | | | Powered Air-Purifying Respirator (PAPR), tight-fitting | Hood or Helmet | SCBA or SCBA + airline, full facepiece and positive pressure |
| Filtering facepiece | | | Elastomeric facepiece | | |  | | | | | | | |

| | | | | | | | | | | | | | |
|--|----|-----|----|-----|----------------|--------------------|---------------------|----|-----|---------------------|------|------|--------|
| Filter efficiency and type | 95 | 100 | 95 | 100 | Organic vapour | 95+ organic vapour | 100+ organic vapour | 95 | 100 | 100+ organic vapour | HEPA | | |
| Assigned Protection Factor* (NIOSH 1987) | 10 | 10 | 10 | 10 | 10 | 10 | 10 | 10 | 50 | 50 | 50 | 1000 | 10,000 |

Silica cont'd

| | | | | | | | | | | | | | |
|--|---|-----------------|-----------------|--|--|--|-----------------|-----------------|---|---|--|--|--|
| Entry—for less than 15 minutes—into a dry mortar-removal or abrasive-blasting area for inspection or sampling where airborne dust is visible | For short-term applications, a filtering facepiece respirator may be appropriate | ✓ N, R, or P | ✓ N, R, or P | | | | | | | | | | |
| Entry into an area where abrasive blasting is being carried out for more than 15 minutes | For short-term applications or applications involving tools or equipment with adequate controls (local exhaust ventilation or water), a half-facepiece respirator may be appropriate | | | | | | | ✓ N, R, or P | | ✓ | | | |
| Dry method dust clean-up from abrasive blasting operations | | | | | | | | ✓ N, R, or P | | ✓ | | | |
| Removal of silica-containing refractory materials with a jackhammer | | | | | | | | ✓ N, R, or P | | ✓ | | | |
| Drilling holes in concrete or rock as part of a tunnelling operation or road construction | | | | | | | | ✓ N, R, or P | | ✓ | | | |
| Using a power tool to cut, grind, or polish concrete, masonry, terrazzo, or refractory materials | | | | | | | | ✓ N, R, or P | | ✓ | | | |
| Using a power tool to remove silica-containing materials | | | | | | | | ✓ N, R, or P | | ✓ | | | |
| Using a power tool indoors to chip or break and remove concrete, masonry, stone, terrazzo, or refractory materials | | | | | | | | ✓ N, R, or P | | ✓ | | | |
| Tunnelling (operation of tunnel boring machine, tunnel drilling, tunnel mesh insulation) | | | | | | | | ✓ N, R, or P | | ✓ | | | |
| Tuckpointing and surface grinding | | | | | | | | ✓ N, R, or P | | ✓ | | | |
| Dry-mortar removal with an electric or pneumatic cutting device | | | | | | | | ✓ N, R, or P | | ✓ | | | |
| Using compressed air outdoors to remove silica dust | | | | | | | ✓ N, R, or P | | ✓ | | | | |

N = Not resistant to oil R = Oil-resistant P = Oil-proof OV = Organic vapour cartridge

Respirator Selection Guide for Common Construction Activities

| | Air purifying | | | | | | | | | | Supplied air | | |
|--|---------------------|-----|-----------------------|-----|----------------|---|---------------------|----|-----|---------------------|--|----------------|--|
| | Half facepiece | | | | | Full facepiece | | | | | Powered Air-Purifying Respirator (PAPR), tight-fitting | Hood or Helmet | SCBA or SCBA + airline, full facepiece and positive pressure |
| | Filtering facepiece | | Elastomeric facepiece | | |  | | | | | | | |
| Filter efficiency and type | 95 | 100 | 95 | 100 | Organic vapour | 95+ organic vapour | 100+ organic vapour | 95 | 100 | 100+ organic vapour | HEPA | | |
| Assigned Protection Factor* (NIOSH 1987) | 10 | 10 | 10 | 10 | 10 | 10 | 10 | 10 | 50 | 50 | 50 | 1000 | 10,000 |

| Synthetic Vitreous Fibres (Man-made mineral fibres) | | | | | | | | | | | | | |
|--|-----------------|-----------------|-----------------|-----------------|--|--|--|--|-----------------|--|---|--|--|
| Installation, removal, or blowing cellulose, fiberglass, mineral wool, or calcium silicate | ✓ N, R, or P | ✓ N, R, or P | ✓ N, R, or P | ✓ N, R, or P | | | | | | | | | |
| Installation of refractory ceramic fibres (silica may be present) | | | | ✓ N, R, or P | | | | | | | | | |
| Removal of refractory ceramic fibres (silica may be present) | | | | | | | | | ✓ N, R, or P | | ✓ | | |

| Other dust and fibre exposure | | | | | | | | | | | | | |
|---|--|--|-----------------|--|--|--|--|--|-------------|-----------------|---|--|--|
| Removal of roofing material (built-up roofing, no asbestos) | ✓ R or P | | ✓ R or P | | | | | | ✓ R or P | | | | |
| Dry method dust clean-up from abrasive blasting operations | For short-term applications or applications involving tools or equipment with adequate controls (local exhaust ventilation or water) a half-facepiece respirator may be appropriate. | | | | | | | | | ✓ N, R, or P | ✓ | | |
| Wood dust, including pressure-treated wood dust | ✓ N, R, or P | | ✓ N, R, or P | | | | | | | | | | |
| Vinyl or laminate floor sanding | ✓ N, R, or P | | ✓ N, R, or P | | | | | | | | | | |

** Protection from ozone may be required in some circumstances. Contact the respirator manufacturer.

N = Not resistant to oil R = Oil-resistant P = Oil-proof OV = Organic vapour cartridge

Respirator Selection Guide for Common Construction Activities

| Air purifying | | | | | | | | | | | Supplied air | |
|---------------------|--|--|-----------------------|--|--|---|--|--|--|----------------|--|--|
| Half facepiece | | | | | | Full facepiece | | | Powered Air-Purifying Respirator (PAPR), tight-fitting | Hood or Helmet | SCBA or SCBA + airline, full facepiece and positive pressure | |
| Filtering facepiece | | | Elastomeric facepiece | | |  | | | | | | |

| | | | | | | | | | | | | | |
|--|----|-----|----|-----|----------------|--------------------|---------------------|----|-----|---------------------|------|------|--------|
| Filter efficiency and type | 95 | 100 | 95 | 100 | Organic vapour | 95+ organic vapour | 100+ organic vapour | 95 | 100 | 100+ organic vapour | HEPA | | |
| Assigned Protection Factor* (NIOSH 1987) | 10 | 10 | 10 | 10 | 10 | 10 | 10 | 10 | 50 | 50 | 50 | 1000 | 10,000 |

| Welding and flame-cutting | | | | | | | | | | | | | | |
|---|-----------------|--|-----------------|-----------------|--|--|--|--|-----------------|--|---|---|--|---|
| Any welding in confined spaces when the atmosphere is not monitored | | | | | | | | | | | | | | ✓ |
| Aluminum** | ✓ N, R, or P | | ✓ N, R, or P | | | | | | | | | | | |
| Mild steel | ✓ N, R, or P | | ✓ N, R, or P | | | | | | | | | | | |
| Stainless steel | ✓ N, R, or P | | ✓ N, R, or P | | | | | | | | | | | |
| Galvanized or plated metals | ✓ N, R, or P | | ✓ N, R, or P | | | | | | | | | | | |
| Lead-painted steel: flame cutting or welding, short-term, not repeated, material stripped before work | | | ✓ N, R, or P | ✓ N, R, or P | | | | | | | | | | |
| Welding or high-temperature cutting of lead-containing coatings or materials indoors or in a confined space | | | | | | | | | ✓ N, R, or P | | ✓ | ✓ | | |

| Miscellaneous | | | | | | | | | | | | | | |
|--|--|--|--|--|-------------|-------------|--|--|--|--|--|--|---|--|
| Epoxy adhesive (large-scale use) | | | | | | | | | | | | | ✓ | |
| Solvents, adhesives, and epoxy (small scale) | | | | | ✓ R or P | | | | | | | | | |
| Caulking compounds, solvent-based, large-scale use | | | | | ✓ R or P | | | | | | | | | |
| Form oil spraying | | | | | ✓ R or P | | | | | | | | | |
| Paving | | | | | | ✓ R or P | | | | | | | | |

N = Not resistant to oil R = Oil-resistant P = Oil-proof OV = Organic vapour cartridge

PERSONAL FALL PROTECTION

Personal fall protection equipment consists of the components shown in the following illustration.

This equipment can be used for travel restraint or fall arrest.

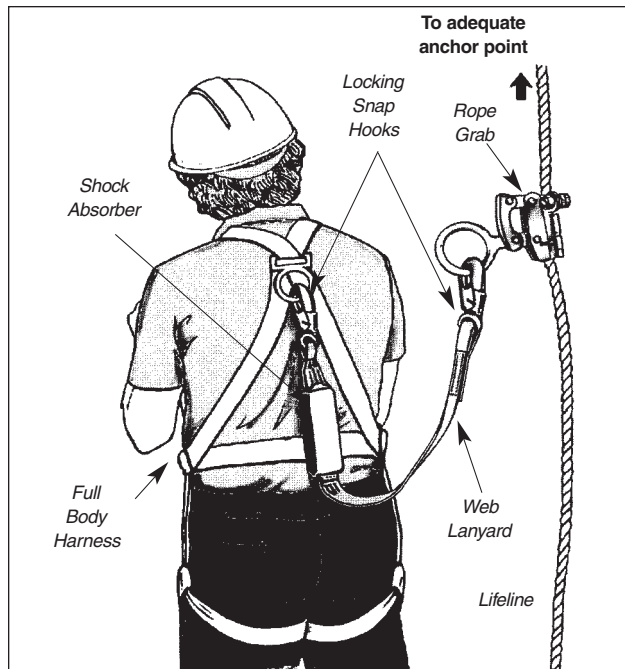

Travel-Restraint Systems

A travel-restraint system lets a worker travel just far enough to reach the edge but not far enough to fall over.

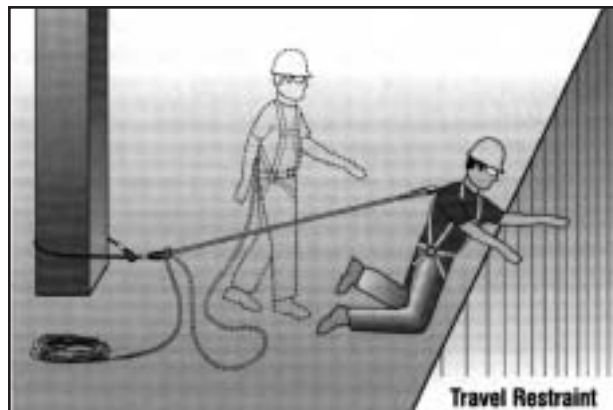

The basic travel-restraint system consists of

- CSA-approved full body harness
- lanyard
- lifeline
- rope grab to attach harness or lanyard to lifeline
- adequate anchorage (capable of supporting a static load of 2 kilonewtons—450 pounds—with a recommended safety factor of at least 2, that is, 4 kilonewtons or 900 pounds).

Travel-restraint arrangements must be thoroughly planned, with careful consideration given to

- selection of appropriate components
- location of adequate anchor points

- identification of every fall hazard in the proposed work area.

Try to select an anchor point that is as close as possible to being

- perpendicular to the unprotected edge, and
- at the centre of the work area.

All fall hazards in the work area must be identified. Pay special attention to work areas with irregular shaped perimeters, floor openings, or locations near corners.

A fully extended lifeline and/or lanyard that adequately restrains a worker from a fall hazard in one section of the work area may be too long to provide the same protection in another section.

Two methods of travel restraint are commonly used in construction.

- 1) Connecting an adequately anchored lifeline directly to the D-ring of the worker's full body harness. It's absolutely critical that the length of the lifeline, measured from the anchor point, is short enough to restrain the worker from any fall hazard.
- 2) Attaching a lanyard from the D-ring of the worker's full body harness to a rope grab on an adequately anchored lifeline. There must be some means—such as a knot in the lifeline—to prevent the rope grab from sliding along the lifeline to a point where the worker is no longer restrained from falling.

Whether method 1 or 2 is used, the system must be adjusted so that the fully extended lifeline and/or lanyard prevents the worker from reaching any point where the worker may fall. The system must also be securely anchored.

Fall-Arrest Systems

Where workers cannot be protected from falls by guardrails or travel restraint, they must be protected by at least one of the following methods:

- fall-restricting system
- safety net
- fall-arrest system.

In the event of a fall, these systems must keep a worker from hitting the ground, the next level below, or any other objects below.

A fall-restricting system is designed to limit a worker's free fall distance to 0.6 metres (2 feet). One type uses a belt grab or belly hook that attaches to a safety rail on a fixed ladder.

A safety net system must be designed by a professional engineer. The system is installed below a work surface where a fall hazard exists.

A fall-arrest system

- must include a CSA-approved full body harness
- must include a lanyard equipped with a shock absorber unless the shock absorber could cause a falling worker to hit the ground or an object or a level below the work
- must include an adequate fixed support; the harness must be connected to it via a lifeline, or via a lanyard and a lifeline

- must prevent a falling worker from hitting the ground or any object or level below the work
- must not subject a falling worker to a peak fall-arrest force greater than 8 kilonewtons.

The construction regulation (O. Reg. 213/91) requires that

- all fall protection equipment must be inspected for damage, wear, and obvious defects by a competent worker before each use
- any worker required to use fall protection must be trained in its safe use and proper maintenance.

Any defective component should be replaced by one that meets or exceeds the manufacturer's minimum performance standards for that particular system.

The regulation also requires that any fall-arrest system involved in a fall be removed from service until the manufacturer certifies all components safe for reuse.

For any worker receiving instruction in fall protection, the manufacturer's instructions for each piece of equipment should be carefully reviewed, with particular attention to warnings and limitations.

Components

The Canadian Standards Association (CSA) provides minimum standards for most components of personal fall protection equipment:

- CAN/CSA-Z259.1-M99 – *Safety Belts and Lanyards*
- CAN/CSA-Z259.2.1-M98 – *Fall Arresters, Vertical Lifelines, and Rails*
- CAN/CSA-Z259.2.2-M98 – *Self-Retracting Devices for Personal Fall-Arrest Systems*
- CAN/CSA-Z259.2.3-M98 – *Descent Control Devices*
- CAN/CSA-Z259.10-M90 – *Full Body Harnesses*
- CAN/CSA-Z259.111-M92 – *Shock Absorbers for Personal Fall-Arrest Systems*
- CAN/CSA-Z259.12-01 – *Connecting Components for Personal Fall-Arrest Systems*.

For any component not covered by these standards, confirm with the manufacturer that the component is suitable for the particular system being considered.

The minimum strength of fall-arrest components depends on whether or not the system uses a shock absorber.

- In systems *without* shock absorbers, all components, including lifeline and lifeline anchorage, must be able to support a static load of at least 8 kilonewtons (1800 pounds) without exceeding the allowable unit stress of the materials used for each component.
- In systems *with* shock absorbers, all components, including lifeline and lifeline anchorage, must be able to support a static load of 6 kilonewtons (1350 pounds) without exceeding the allowable unit stress of the materials used for each component.

In designing both systems, it is recommended that a safety factor of at least two be applied to the stated minimum load capacity. In practical terms, anchorage should be strong enough to support the weight of a small car (about 3600 pounds).

Lifelines

There are three basic types of lifelines:

- 1) vertical
- 2) horizontal
- 3) retractable.

All lifelines must be inspected daily to ensure that they are

- free of cuts, burns, frayed strands, abrasions, and other defects or signs of damage
- free of discolouration and brittleness indicating heat or chemical exposure.

1) Vertical Lifelines

Vertical lifelines must comply with the current edition of the applicable CSA standard and the following minimum requirements:

- Only one person at a time may use a vertical lifeline.
- A vertical lifeline must reach the ground or a level above ground where the worker can safely exit.
- A vertical lifeline must have a positive stop to prevent the rope grab from running off the end of the lifeline.

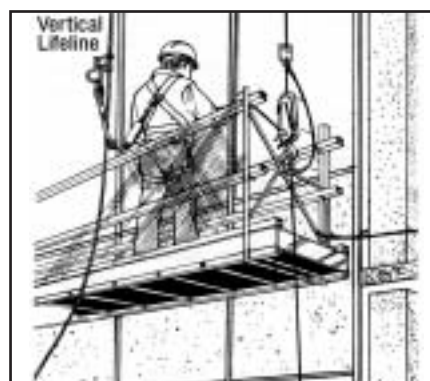

Vertical lifelines are typically 16-millimetre (5/8-inch) synthetic rope (polypropylene blends).

2) Horizontal Lifelines

The following requirements apply to any horizontal lifeline system:

- The system must be designed by a professional engineer according to good engineering practice.
- The design can be a standard design or specifically engineered for the site.

The design for a horizontal lifeline system must

- ✓ clearly indicate how the system is to be arranged, including how and where it is to be anchored
- ✓ list and specify all required components
- ✓ clearly state the number of workers that can safely be attached to the lifeline at one time
- ✓ spell out instructions for installation, inspection, and maintenance
- ✓ specify all of the design loads used to design the system.

The system must be installed, inspected, and maintained in accordance with the professional engineer's design.

Before each use, the system must be inspected by a professional engineer or competent worker designated by a supervisor. A complete and current copy of the design must be kept on site as long as the system is in use.



CAUTION: The construction regulation requires that "a horizontal or vertical lifeline shall be kept free from splices or knots, except knots used to connect it to a fixed support." Knots along the length of either a horizontal or vertical lifeline can reduce its strength by as much as 40%.

3) Retractable Lifelines

Retractable lifelines consist of a lifeline spooled on a retracting device attached to adequate anchorage. Retractable lifelines must comply with CAN/CSA-Z259.2.2-M98.

In general, retractable lifelines

- are usually designed to be anchored above the worker
- employ a locking mechanism that lets line unwind off the drum under the slight tension caused by a user's normal movements
- automatically retract when tension is removed, thereby preventing slack in the line
- lock up when a quick movement, such as that caused by a fall, is applied
- are designed to minimize fall distance and the forces exerted on a worker's body by fall arrest.

Always refer to the manufacturer's instructions regarding use, including whether a shock absorber is recommended with the system.

Any retractable lifeline involved in a fall arrest must be removed from service until the manufacturer or a qualified testing company has certified it for reuse.

Lifeline Hazards

Ultraviolet light – Exposure to the sun may damage or weaken synthetic lifelines. Ensure that material being considered for lifelines is UV-resistant.

Temperature – Extreme heat can weaken or damage some lifelines while extreme cold can make others brittle. Ensure that material being considered for lifelines can stand up to the most extreme conditions expected.

Friction and abrasion – Normal movement may wear, abrade, or otherwise damage lifelines in contact with sharp or rough surfaces. Protection such as wood softeners or rubber mats can be used at contact points to prevent wear and tear.

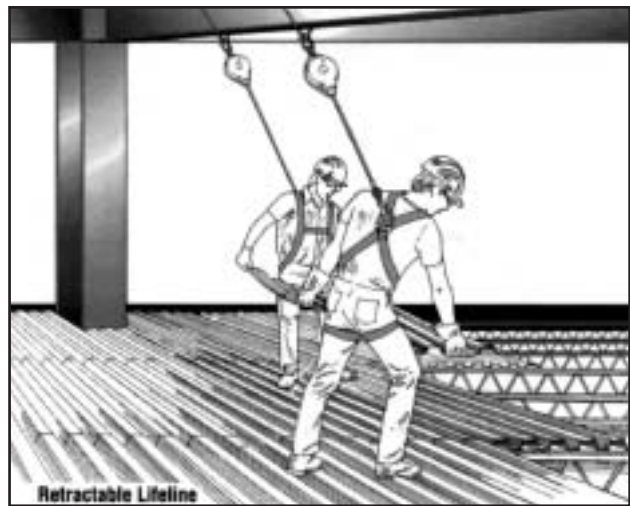

Sparks or flame – Hot work such as welding or flame cutting can burn, melt, cut, or otherwise damage a lifeline. Ensure that material being considered for lifelines is flame-resistant or provide appropriate protection where sparks or flame may be encountered.

Chemicals – Chemical exposure can burn or degrade a lifeline very quickly. Ensure that material being considered for lifelines will resist any chemicals encountered on the job.

Storage – Always store lifelines separately. Never store them where they may contact hazards such as sharp objects, chemicals, or gasoline.

Anchor Systems

There are three basic types of anchor systems for fall protection:

- 1) **designed fixed support** – load-rated anchors specifically designed and permanently installed for fall protection purposes as an integral part of the building or structure (for example, roof anchors on high-rise buildings)
- 2) **temporary fixed support** – anchor systems designed to be connected to the structure using specific installation instructions (for example, nail-on anchors used by shinglers)
- 3) **existing structural features or equipment not intended as anchor points but verified by a professional engineer or competent person as having adequate capacity to serve as anchor points** (for example, rooftop mechanical rooms, structural steel, or reinforced concrete columns).

Designed fixed support can be used to anchor a fall-arrest system, fall-restricting system, or travel-restraint system if the support has been installed according to the *Building Code* and is safe and practical to use.

Temporary fixed support can be used as anchorage if it meets the following conditions:

- ✓ it can support at least 8 kilonewtons (1800 pounds) without exceeding the allowable unit stress for each material used;
- ✓ when used with a fall-arrest system incorporating a shock absorber, it can support at least 6 kilonewtons (1350 pounds) without exceeding the allowable unit stress for each material used; or



Examples of adequate anchorage

- ✓ when used with a travel-restraint system, it can support at least 2 kilonewtons (450 pounds) without exceeding the allowable unit stress for each material used.

In all cases, a **safety factor of at least two** should be applied when determining the minimum load that an anchor point must support.

As a general rule with fall-arrest systems, choose an anchor capable of supporting the weight of a small car (about 3600 pounds).

When existing structural features or equipment are used as anchor points, avoid corners or edges that could cut, chafe, or abrade fall protection components.

Where necessary, use softeners such as wood blocking to protect connecting devices, lifelines, or lanyards from damage.

Never anchor to

- roof vents or stink pipes
- roof hatches
- small pipes and ducts
- metal chimneys
- TV antennas
- stair or balcony railings.

Full Body Harness

- Chest strap should be adjusted so that it's snug and located near the middle of the chest. In a headfirst fall a properly adjusted chest strap will prevent the worker from coming out of the harness.
- Leg straps should be adjusted so the user's fist can fit snugly between strap and leg.
- Harness straps should be adjusted to put the D-ring between the shoulder blades. A properly positioned D-ring will keep a worker upright after fall arrest.

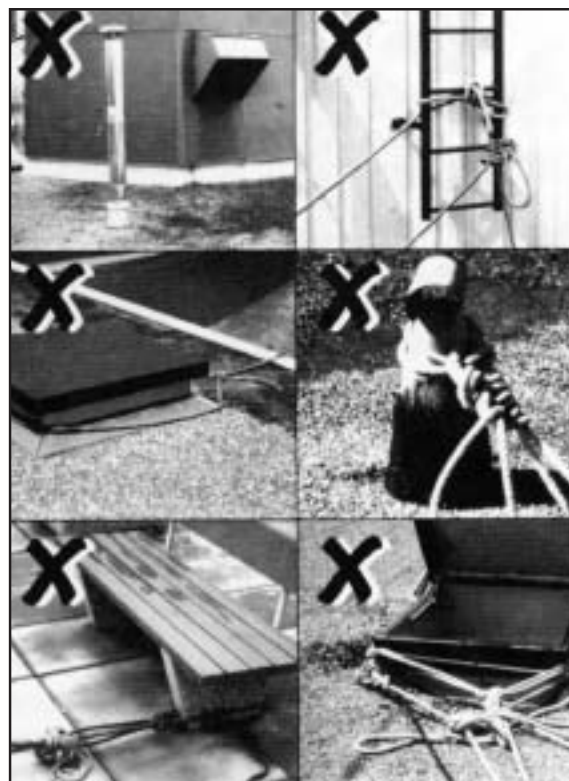

Examples of inadequate anchorage

Inspect harness for

- ✓ burns, cuts, or signs of chemical damage
- ✓ loose or broken stitching
- ✓ frayed web material
- ✓ D-ring and keeper pads free from distortion and signs of undue wear or damage
- ✓ grommets and buckles free of damage, distortion, or sharp edges.

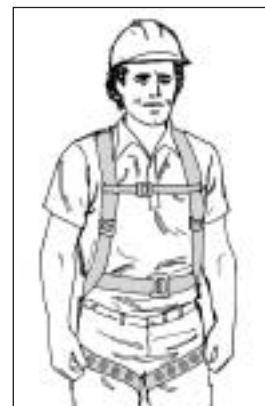

Lanyards

- Use manufactured lanyards only. They can be made of wire rope, synthetic fibre rope, or synthetic webbing.
- Lanyards are manufactured to specific lengths. Never try to shorten a lanyard by tying knots in it. Knots can seriously reduce its rated strength.
- Never store lanyards around chemicals, sharp objects, or in wet places. Never leave them exposed for long periods to direct sunlight.
- Inspect lanyards for
 - ✓ burns, cuts, or signs of chemical damage
 - ✓ loose or broken stitching
 - ✓ frayed web material.

Shock Absorbers

- Shock absorbers absorb some of the force generated by fall arrest. Shock absorbers can be purchased as separate equipment or built into lanyards.
- One end of the shock absorber must be connected to the D-ring on the full body harness.
- In most cases the shock-absorbing component is

enclosed in a snug-fitting jacket to protect it from the user's day-to-day activities. In a fall, the jacket tears open as the shock absorber deploys.

- Check the cover jacket for stress or tearing (many shock absorbers have a tag on the jacket that tears if the unit is exposed to a shock load—make sure this tag is intact).
- Ensure that a shock absorber built into a lanyard has a constant cross-section or diameter.

Connecting Devices

Locking Snap Hook – has a spring-loaded keeper across the opening of the hook that cannot be opened unless the locking mechanism is depressed.

Karabiner (D-Clip) – designed not to open under twist loads. To open the gate or keeper requires two separate actions: 1) twisting the locking mechanism and (2) pulling the locking mechanism back. When released, the spring-loaded locking mechanism flicks back into the locked position.

Rope Grab – used to connect lanyard to lifeline. These devices can be moved up and down the lifeline when a steady force is applied but will lock when a sharp tug or pull is applied. They will remain locked on the lifeline until the applied force is released.

Each rope grab is designed and manufactured for use with a specific diameter and type of lifeline. **Rope grab and lifeline must be compatible.** Specifications are usually listed on the housing.

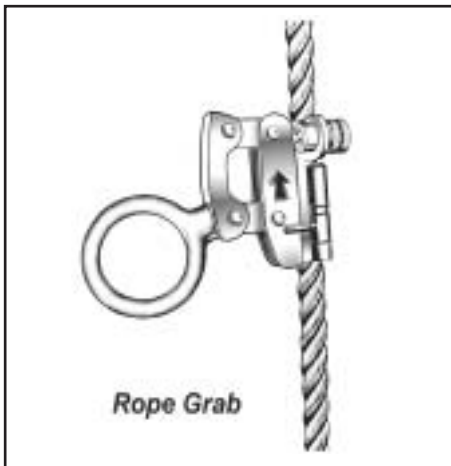

The rope grab must also be attached to the lifeline in the correct direction—not upside down. On most rope grabs an arrow indicates the direction in which to orient the device. In addition, each rope grab is designed for use with a specific length of lanyard, normally two or three feet maximum.

Check all connecting devices for

- ✓ damage, cracking, dents, bends, or signs of deformation
- ✓ connecting rings centred—not bent to one side or otherwise deformed
- ✓ rust
- ✓ moving parts working smoothly
- ✓ signs of wear or metal fatigue.

Fall-Arrest Planning

Before deciding on a fall-arrest system, assess the hazards a worker may be exposed to in case of a fall.

Before the fall is arrested, will the worker "bottom out," that is, hit ground, material, equipment, or a lower level of the structure? Will the pendulum effect cause the worker to swing from side to side, possibly striking equipment, material, or structure? In the event of fall arrest, how will the suspended worker be rescued? Planning must take into account these and other concerns.

Total Fall Distance is the distance required to fully arrest a fall. It consists of

- Free Fall Distance, which should be kept to 1.5 metres (5 feet) or less, plus
- Fall Stopping Distance, which includes stretch in the lanyard (minimal) and lifeline, slack in the harness (maximum 30 cm or 1 foot due to allowable adjustments for user's comfort), and deployment of the shock absorber (maximum 1.1 metres—or 42 inches).

Free Fall Distance is measured from the D-ring of a worker standing on the work surface down to the point where either the lanyard or the shock absorber begins to arrest the fall. It is strongly recommended that this distance be kept as short as possible.

To minimize free fall, workers should tie off to an anchor overhead and use as short a lanyard as the work will allow.

Where a worker is connected to a vertical lifeline by a rope grab, the rope grab should be positioned as high above the D-ring as the work will allow. By doing this, the worker minimizes not only the Free Fall Distance but also the Fall Stopping Distance required to completely arrest a fall.

Bottoming Out

Bottoming out occurs when a falling worker hits a lower level, the ground, or some other hazard before the fall is fully arrested.

This occurs when Total Fall Distance is greater than the distance from the work surface to the next level, the ground, or some other hazard below.

Fall-arrest systems must be planned, designed, and installed to prevent any risk of bottoming out.

Pendulum Effect

The farther you move sideways from your anchor point, the greater the chance of swinging if you fall. This is known as the "pendulum effect." And the more you swing, the greater the force with

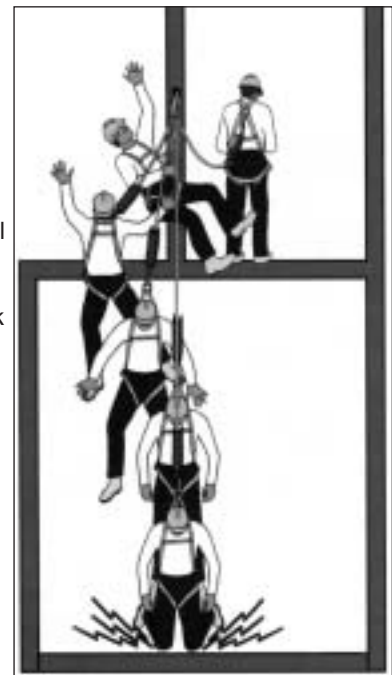

which you'll strike columns, walls, frames, or other objects in your path.

Swinging may even cause your taut lanyard or lifeline to break where it runs over rough or sharp edges.



Swing Fall or Pendulum Effect

To minimize pendulum effect, workers should keep lanyard or lifeline perpendicular from edge to anchor. Where work extends along an open edge, anchor points can be changed to keep lanyard or lifeline perpendicular as work progresses.

Another solution is to run a horizontal lifeline parallel to the edge. The worker attaches lanyard to lifeline, moves along the edge, and the lanyard travels at the same pace, remaining close to perpendicular at all times.

Emergency Rescue

The construction regulation (O. Reg. 213/91) requires that before workers use any fall-arrest system or safety net on a project, the employer must develop written rescue procedures. It's important that a worker involved in a fall arrest be brought to a safe area as quickly as possible without causing injury or putting rescuers at risk.

In many cases, the rescue plan can be simple. A ladder or elevating work platform can be used to reach suspended workers and get them down safely. Other workers may be hauled back up to the level from which they fell or pulled in through a nearby window or other opening.

In other cases, procedures may be more complicated. For instance, workers trapped on a failed swingstage, or hanging from it, may need to be rescued by specially trained and equipped personnel from the local fire department. Aerial ladder trucks or other high-reach equipment may be necessary. In extreme cases, the fire department may use rappelling techniques to reach trapped workers and lift or lower them to a safe level.

Plans should cover the on-site equipment, personnel, and procedures for different types of rescue. Any off-site rescue services that might be required should be contacted and arranged in advance to familiarize them with the project. CSAO's Emergency Response poster

(P103) can be used to indicate the nearest hospital and the phone numbers of fire, ambulance, and police services.

Site management must ensure that

- everyone on site is aware of the rescue plan
- equipment and other resources are available
- designated personnel are properly trained.

Workers must receive training from their employer regarding the specific fall protection equipment and procedures they will use. Products differ not only between manufacturers but also between product lines in a single company. Training must therefore cover the exact harness, lanyard, shock absorber, rope grab, lifeline, and anchorage each worker will rely on, as well as the applications to be encountered.

Conclusion

Employers, supervisors, and workers all have responsibilities in reducing or eliminating falls in construction.

This section has provided guidelines for fall protection, including both fall prevention and fall arrest. But the information means nothing unless employers, supervisors, and workers apply it on the job.

Workers who have any questions about fall hazards or fall protection should ask their supervisor. When it comes to fall protection, make sure you know how the equipment works and how to use it. Your life depends on it.

HAND/SKIN PROTECTION

In construction, exposed hands and skin are susceptible to physical, chemical, and radiation hazards. Personal hand/skin protection is often the only practical means of preventing injury from

- physical hazards—sharp or jagged edges on materials and tools; heat; vibration
- corrosive or toxic chemicals
- ultraviolet radiation.

Physical Hazards

For physical hazards such as sharp edges, splinters, and heat, leather gloves are the preferred protection. Cotton or other materials do not stand up well and are recommended only for light-duty jobs.

Vibration transferred from tools and equipment can affect hands and arms. One result may be hand/arm vibration syndrome (HAVS). This disease causes the following changes in fingers and hands:

- circulation problems such as whitening or bluish discoloration, especially after exposure to cold
- sensory problems such as numbness and tingling
- musculoskeletal problems such as difficulty with fine motor movements—for instance, picking up small objects.

Workers who use vibrating tools such as jackhammers, grinders, riveters, and compactors on a daily basis may develop HAVS. Preventing this disease requires cooperation between employers and workers.

Employers

- Provide power tools with built-in vibration-reducing components.
- Review exposure times and allow rest breaks away from vibrating tools.
- Ensure proper tool maintenance (worn grinding wheels or tool bearings can lead to higher vibration levels).
- Train exposed workers in prevention techniques.
- Provide anti-vibration gloves.

Workers

- Wear appropriate clothing in cooler weather to maintain core body temperature.
- Wear gloves whenever possible.
- Wear anti-vibration gloves when using power tools and equipment.
- Avoid smoking (smoking contributes to circulatory problems).
- Report any poorly functioning tools immediately.

Chemical Hazards

For protection against chemical hazards, the material safety data sheet (MSDS) for the product being used should identify whether gloves are needed and what they should be made of. MSDSs must be available on site for all controlled products being used.

Table 1: Glove Selection Chart

| Chemical Name | Glove Selection |
|--|-----------------------|
| Acetone | Butyl Rubber |
| Cellosolve | PVA, PVC, Neoprene |
| Cellosolve Acetate | PVA, PVC |
| Cyclohexane | NBR, Viton® |
| Hexane | Neoprene, NBR, PVA |
| Methyl Alcohol | Neoprene, Rubber, NBR |
| Methyl Chloroform | PVA, Viton |
| Methylene Chloride | PVA, Viton |
| Methyl Ethyl Ketone | Butyl Rubber |
| Methyl Isobutyl Ketone | Butyl Rubber, PVA |
| Mineral Spirits | Neoprene |
| Naphtha | NBR, PVA |
| Perchloroethylene | NBR, PVA, Viton |
| Stoddard Solvent | PVA, NBR, Rubber |
| Toluene | PVA, Viton |
| Turpentine | PVA, NBR |
| Trichloroethylene | PVA, Viton |
| 1, 1, 1 Trichloroethane | PVA, Viton |
| 1, 1, 2 Trichloroethane | PVA, Viton |
| Xylene | PVA, Viton |
| PVA – Polyvinyl Alcohol PVC – Polyvinyl Chloride NBR – Nitrite Butyl Rubber Viton® – Dupont tradename product | |

Table 1 identifies glove materials to be worn for protection against chemicals that may injure the skin. This information can be used when the MSDS does not specify the type of glove to be worn.

CAUTION: Common glove materials have limited protective properties and do not protect against all hazards. Some solvents, degreasers, and other liquids can penetrate and/or dissolve rubber, neoprene, or PVC.

Ultraviolet Radiation

In recent years there has been growing concern over the health risks of exposure to the sun's ultraviolet (UV) radiation. Construction workers are particularly at risk because they often work outdoors.

Long-term health risks of UV exposure include skin cancer. Every year there has been an alarming increase in the incidence of skin cancer. Sunlight is the main source of UV radiation known to damage the skin and cause skin cancer. Exposure to the sun's UV radiation is widely recognized as a *highly preventable* cause of skin cancer.

Melanoma is the least common but most dangerous type of skin cancer. The incidence of melanoma in men is rising faster than all other cancers. According to the Canadian Dermatology Association (CDA), the mortality rate from malignant melanoma is increasing, particularly in middle-aged males.

Melanomas most often appear on the upper back, head, and neck. The CDA also notes that there is generally a lag time of 10 to 30 years for the clinical appearance of skin cancer to occur. Consequently, it is critical for young workers to beware of the cumulative effect of unprotected sun exposure. The more time they spend unprotected in the sun, the higher the risk of developing skin cancer.

Although most construction workers generally cover up their arms, legs, and torso on site, their faces and necks are still exposed to the sun's harmful rays. In addition, areas like the tips of the ears and the lips are often overlooked when it comes to sun protection.

The type of skin cancer that develops on the ear or the lip has a high chance of spreading to other parts of the body and causing death. Melanoma may also occur on the sun-exposed parts of the head and neck.

In fact the majority of skin cancers (2 out of 3) occur on the head and neck, followed by the forearm and back of the hand. Workers too often leave these critical areas exposed to the harmful effects of UV radiation.

Individual risk factors for developing skin cancer include

- fair skin that burns easily
- blistering sunburns in childhood and adolescence
- family history of melanoma
- many freckles and moles.

In addition to the harmful effects of the sun's direct rays, some workers may be exposed to indirect UV radiation. Workers can receive additional radiation if they are on or near a surface that reflects sunlight. Reflective surfaces such as concrete, water, unpainted corrugated steel, building glass, and aluminum can increase the amount of ultraviolet radiation to which a worker is exposed.

Another source of indirect UV radiation is from the hard hat itself. UV rays can reflect off the hard hat onto a worker's face, magnifying the amount of UV exposure.

Although all construction workers are at risk, those who don't have ready access to shade and/or work at heights are at a higher risk for UV overexposure. These trades include

- concrete finishing workers
- roofers
- rodworkers
- formworkers on high-rise and residential sites
- roadworkers
- traffic signallers
- ironworkers.

In addition, working at sites with southern exposure decreases the daytime shade available and increases UV exposure.

Remember—even on cloudy or hazy days, UV radiation can penetrate the atmosphere and burn your skin.

What Workers Can Do

- ✓ Apply a broad-spectrum sunscreen with a sun protection factor (SPF) of 15 or greater to all exposed skin areas. Be sure to cover your ears and the back of your neck. Apply sunscreen 20 to 30 minutes before you go out in the sun. Reapply sunscreen every 2 hours.
- ✓ Use an SPF 15 or higher sunscreen lip balm and reapply every two hours. Skin cancers can develop on lips.
- ✓ You may add UV protection to the back of your neck by using fabric to block the sun's rays. Neck protectors that clip onto your hardhat are available.
- ✓ Wear UV-absorbent safety glasses (CSA-approved polycarbonate glasses incorporate this feature).
- ✓ Wear clothing that covers as much of the skin as possible. Tightly woven material will offer greater protection as a physical block to UV rays.
- ✓ If you sweat heavily, you may need to reapply sunscreen more often. Additionally, when clothing is wet, it loses some of its ability to block out the sun's rays. Ensure you have additional dry clothing if necessary.
- ✓ Try to find a shaded area for your breaks and lunch.
- ✓ Wear a wide-brim hard hat designed to protect your face and neck from the sun. Adding a glare guard under the peak of your hard hat will help reduce reflective UV rays.
- ✓ Examine your skin regularly for any unusual changes. The most important warning sign for skin cancer is a spot on the skin that is changing in size, shape, or colour. The danger signs include any wound or skin patch that doesn't heal properly or scales. Be particularly attentive to any mole that grows or becomes irregular in shape, especially if it is multi-coloured. If anything looks unusual, see your doctor as soon as possible. **Skin cancers detected early can almost always be cured.**

What Employers Can Do

- ✓ Supply workers with a broad-spectrum sunscreen with an SPF of 15 or higher.
- ✓ Ensure adequate shaded areas for workers on breaks and lunch.
- ✓ If possible, rotate workers to shaded areas of the jobsite.
- ✓ Educate workers on the hazards of UV radiation.
- ✓ Ensure that workers use UV-absorbent safety glasses.

The majority of skin cancers are preventable. Taking basic precautions can significantly reduce the health effects of chronic sun exposure.

HIGH-VISIBILITY CLOTHING

The construction regulation (O. Reg. 213/91) requires that any worker who may be endangered by vehicular traffic on a project must wear a garment that provides a high level of visibility.



There are two distinct features to high-visibility clothing.

Background Material

This is the fabric from which the garment is made. It must be fluorescent orange or bright orange in colour and afford increased daytime visibility to the wearer. Fluorescent orange provides a higher level of daytime visibility and is recommended.

Retroreflective Stripes or Bands

The stripes or bands must be fluorescent and retroreflective and be arranged on the garment with two vertical stripes down the front and forming an X on the back. The stripes must be yellow and 50 mm wide. Retroreflective stripes are to afford the worker both low-light and night-time visibility.

For night-time work, additional stripes or bands are required on the arms and legs. One way to meet this requirement is to dress workers in fluorescent orange coveralls with retroreflective bands or stripes attached.

Risk Assessment

Before selecting high-visibility garments, assess the risks to be controlled. Workers who require greater visibility, such as roadway construction workers, should wear clothing that is highly conspicuous under the conditions expected.

For further recommendations on high-visibility clothing, consult CSA's standard Z96-02.