

grease to use properly. The hazards of overexertion and tendinitis can be aggravated by using a dull iron or too short a plane.

Use the plane suited to the job and keep the iron sharp.

For long surfaces like door edges, use a fore plane 18" long and 2 3/8" wide or a jointer plane 24" long and 2 5/8" wide.

For shorter surfaces, use a jack plane 15" long and 2 3/8" wide or a smoothing plane 10" long and 2 3/8" wide.

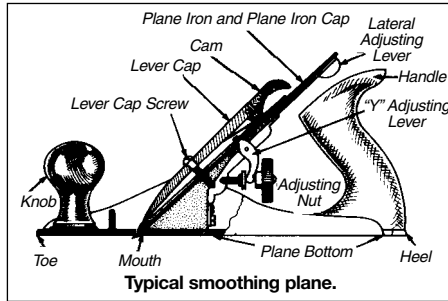

Remember that sharp tools require less effort and reduce the risk of fatigue, overexertion, and back strain.

Work can also be easier with a door jack (page 182) and supports on your work bench.

**Plumb Bobs**

The weight of a mercury-filled plumb bob will surprise you. Designed for use in windy conditions, the bob has considerable weight in proportion to its surface area.

The weight and point of the bob can make it dangerous. Ensure that all is clear below when you lower the bob.

Don't let it fall out of your pocket, apron, or tool bag. The same goes for the standard solid bob.

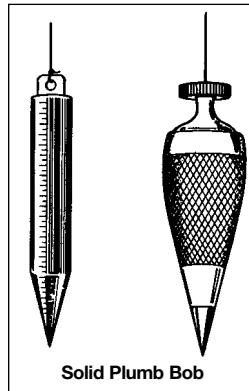

**Crow Bars**

Any steel bar 25-150 cm long and sharpened at one end is often called a crow bar.

The tools include pry bars, pinch bars, and wrecking bars. Shorter ones usually have a curved claw for pulling nails and a sharp, angled end for prying.

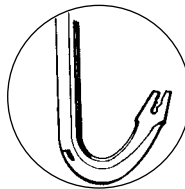

**Nail Pulling**

Pulling out nails can be easier with a crow bar than a claw hammer.

In some cases, a nail-puller does the job best. Keep the hand holding the claw well away from the striking handle.

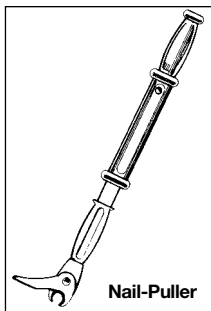

**Lifting**

Loads levered, lifted, or shifted by bars can land on fingers and toes.

- Make sure to clear the area and maintain control of the load.
- Have enough rollers and blocking ready.

- Never – not even for a split second – put fingers or toes under the load.

**General**

Try to avoid prying, pulling, wedging, or lifting at sharp angles or overhead.

Wherever possible, keep the bar at right angles to the work.

Wear eye protection and, where necessary, face protection.

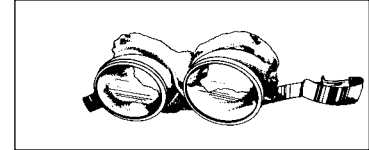

**2 POWER TOOLS — DRILLS, PLANES, ROUTERS**

**Safety Basics**

- Make sure that electric tools are properly grounded or double-insulated.
- Never remove or tamper with safety devices.
- Study the manufacturer's instructions before operating any new or unfamiliar electric tool.
- Regulations require that ground fault circuit interrupters (GFCIs) be used with any portable electric tool operated outdoors or in wet locations.
- Before making adjustments or changing attachments, always disconnect the tool from the power source.
- When operating electric tools, always wear eye protection.
- When operating tools in confined spaces or for prolonged periods, wear hearing protection.
- Make sure that the tool is held firmly and the material properly secured before turning on the tool.

**Drills**

**Types**

With suitable attachments, the drill can be used for disk sanding, sawing holes, driving screws, and grinding.

However, when such applications are repeatedly or continuously required, tools specifically designed for the work should be used.

Trim carpenters will generally select a 1/4 or 3/8 inch trigger-controlled variable speed drill (Figure 129). Simply by increasing pressure on the trigger, the operator can change drill speed from 0 to 2,000 rpm.

Carpenters working in heavy structural construction such as bridges, trusses, and waterfront piers will usually select the slower but more powerful one- or two-speed reversible 1/2 or 3/4 inch drill (Figure 130a).

Size of the drill is determined by the maximum opening of the chuck. For instance, a 3/8 inch drill will take only bits or attachments with a shank up to 3/8 inch wide.

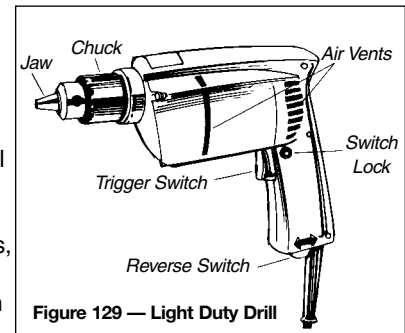

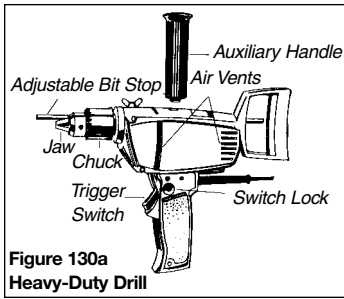

**Figure 130a**  
Heavy-Duty Drill

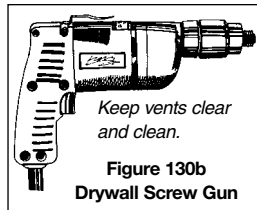

**Figure 130b**  
Drywall Screw Gun

For drywall screws, a drywall screw gun (Figure 130b) should be

used. The driving bit should be replaced when worn. Select a gun that can hang from your tool belt so it does not have to be continuously hand-held.

**Attachments**

Attachments such as speed-reducing screwdrivers, disk sanders, and buffers (Figure 131) can help prevent fatigue and undue muscle strain. A right-angle drive attachment (Figure 132) is very useful in tight corners and other hard-to-reach places.

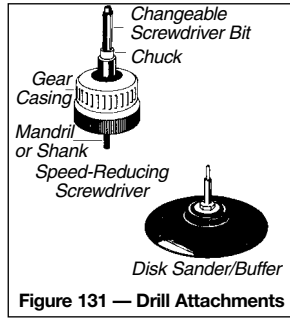

**Figure 131** — Drill Attachments

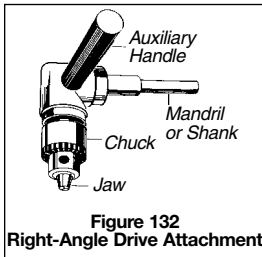

**Figure 132**  
Right-Angle Drive Attachment

Cutting and drilling attachments must be kept sharp to avoid overloading the motor. Operators should not crowd or push the tool beyond capacity. Such handling can burn out the motor, ruin the material, and injure the operator in the event of a kickback.

Some attachments, such as hole saws, spade bits, and screwdrivers (Figure 133), require considerable control by the operator. If the operator does not feed the attachment slowly and carefully into the material, the drill can suddenly stop and severely twist or break the operator's arm. Stock should be clamped or otherwise secured to prevent it from moving. This will also enable the operator to control the tool with both hands and absorb sudden twists or stops caused by obstructions such as knots or hidden nails.

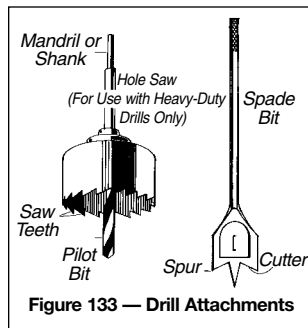

**Figure 133** — Drill Attachments

Operators must restrain the drill just before the bit or cutting attachment emerges through the material, especially when oversized spade bits are used. Sides of the bit often become hooked on the ragged edge of the nearly completed hole and make the drill come to a sudden stop that can wrench the operator's arm.

At the first sign of the bit breaking through the material, the operator should withdraw the drill and complete the work from the other side. This will produce a cleaner job and prevent the material from cracking or splintering.

The same result can be obtained by clamping a back-up piece to the material and drilling into that.

Select the bit or attachment suitable to the size of the drill and the work to be done. To operate safely and efficiently, the shanks of bits and attachments must turn true.

Make sure that the bit or attachment is properly seated and tightened in the chuck.

Some operations require the use of an impact or hammer drill. For instance, drilling large holes in concrete or rock with a carboloy bit should be done with an impact drill (Figure 134).

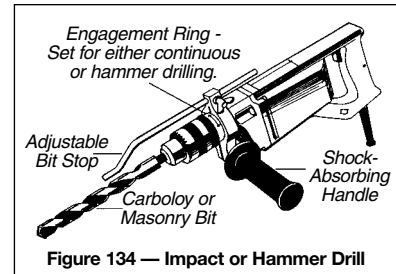

**Figure 134** — Impact or Hammer Drill

Follow manufacturer's instructions when selecting and using a bit or attachment, especially with drills or work unfamiliar to you.

**Working with Small Pieces**

Drilling into small pieces of material may look harmless, but if the pieces are not clamped down and supported, they can spin with the bit before the hole is completed.

If a small piece starts to twist or spin with the drill, the operator can be injured. Small work pieces should be properly secured and supported. Never try to drill with one hand and hold a small piece of material with the other.

**Drilling from Ladders**

Standing on a ladder to drill holes in walls and ceilings (Figure 135) can be hazardous. The top and bottom of the ladder must be secured to prevent the ladder from slipping or sliding when the operator puts pressure on the drill.

When drilling from a ladder, never reach out to either side.

Overreaching can cause the ladder to slide or tip.

Never stand on the top step or paint shelf of a stepladder. Stand at least two steps down from the top. When working from an extension ladder, stand no higher than the fourth rung from the top.

When drilling from a ladder, never support yourself by holding onto a pipe or any other grounded object. Electric current can travel from the hand holding the drill through your heart to the hand holding the pipe.

A minor shock can make you lose your balance. A major shock can badly burn or even kill you.

**Operation**

Always plug in the drill with the switch **OFF**.

Before starting to drill, turn on the tool for a moment to make sure that the shank of the bit or attachment is centred and running true.

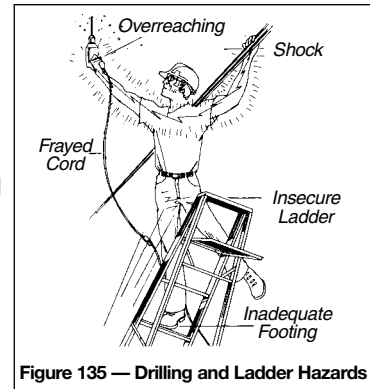
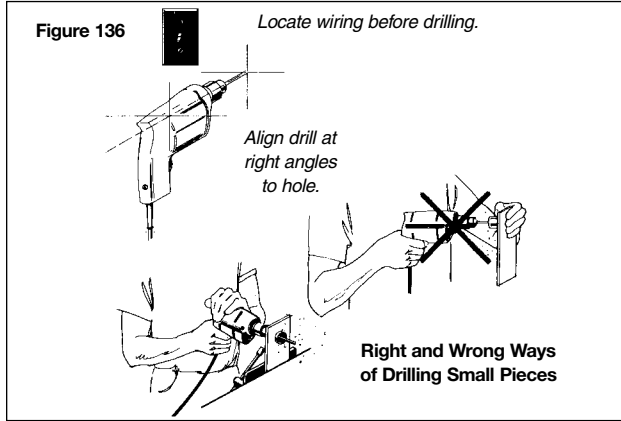

**Figure 135** — Drilling and Ladder Hazards

Punch a layout hole or drill a pilot hole in the material so that the bit won't slip or slide when your start drilling. A pilot hole is particularly important for drilling into hard material such as concrete or metal.

With the drill **OFF**, put the point of the bit in the pilot hole or punched layout hole.

Hold the drill firmly in one hand or, if necessary, in both hands at the correct drilling angle (Figure 136).



Turn on the switch and feed the drill into the material with the pressure and control required by the size of the drill and the type of material.

Don't try to enlarge a hole by reaming it out with the sides of the bit. Switch to a larger bit.

While drilling deep holes, especially with a twist bit, withdraw the drill several times with the motor running to clear the cuttings.

Never support material on your knee while drilling. Material should be firmly supported on a bench or other work surface for drilling.

Unplug the drill and remove the bit as soon as you have finished that phase of your work.

When drilling into floors, ceilings, and walls, beware of plumbing and especially of wiring.

Large rotary and hammer drills can generate extreme torque and must be handled with caution.

Remember that the longer you work, the heavier the drill feels, particularly when working overhead. Take a breather now and then to relax your arms and shoulders.

**Drilling Timbers**

When drilling timbers with a self-feeding auger bit (Figure 137), do not underestimate the physical pressure required to maintain control of the tool. Such work calls for a heavy-duty, low-rpm drill, 1/2 or 3/4 inch in size.

Never attempt to drill heavy timbers by yourself, especially when working on a scaffold or other work platform. If the self-feeding auger bit digs into a hidden knot or other obstruction, the sudden torque can twist or wrench your arm and throw you off balance.

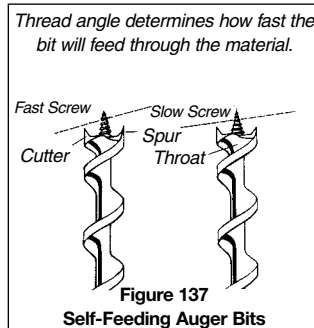

**Other Materials**

The main hazard in drilling materials other than wood is leaning too heavily on the tool. This can not only overload and burn out the motor but also cause injury if you are thrown off balance by the drill suddenly twisting or stopping.

Always use a drill powerful enough for the job and a bit or attachment suited to the size of the drill and the nature of the work. As at other times, punching a layout hole or drilling a pilot hole can make the job safer and more efficient.

A drill press stand (Figure 138) is ideal for drilling holes in metal accurately and safely. Small pieces can be clamped in a vise and bolted to the table. This prevents the workpiece from spinning when the drill penetrates the metal.

A drill press can also be used for cutting large holes in wood with a hole saw or speed bit. The stability of the press and the operator's control over cutting speed eliminate sudden torque.

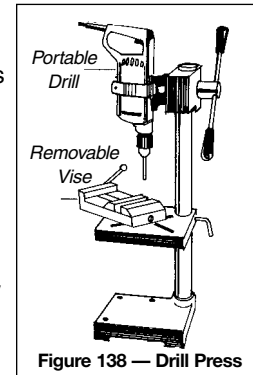

**Planes**

Available in various types and sizes, electric planes are generally operated in similar ways. Adjustments between models may differ, however, depending on specific features.

Planes may be equipped with

- outfeed tables (back shoes) that are either fixed or movable
- infeed tables (front shoes) that move straight up and down or move up and down on an angle to keep the gap between cutter head and table as small as possible
- cutter heads with two or more straight blades (also called knives or cutter blades)
- cutter heads with two curved blades.

Never operate an electric plane while wearing a scarf, open jacket, or other loose clothing. Always wear eye protection and practice good housekeeping.

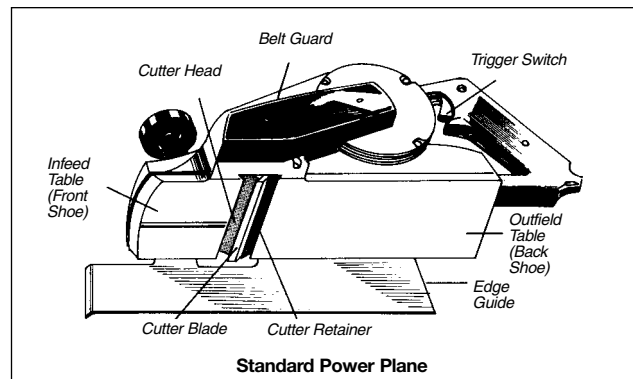

**Standard Plane**

- Hold with both hands to avoid contact with cutter blades.
- Always keep both hands on the plane until motor stops.

- Use the edge guide to direct the plane along the desired cut. Never try to guide the plane with your fingers. If the plane runs into an obstruction or starts to vibrate, your fingers can slide into the unprotected cutter head.

**Block Plane (Electric)**

Designed for use on small surfaces, the block plane is necessarily operated with only one hand. Though convenient and useful, it is more dangerous than the larger, standard plane.

Operators tend to support the work with one hand while operating the block plane with the other. Any unexpected twist or movement can force the plane or the material to kick back and injure the operator. Keep your free hand well out of the way, in case the plane slips accidentally.

**Maintaining Blades**

- Avoid striking staples, nails, sand, or other foreign objects. The first step in operation is to make sure the work is free of obstructions.
- Keep blades in good condition and sharp. A sharp blade is safer to use than a dull blade that has to be held down and forced. A dull blade tends to float over the work and can bounce off, injuring the operator.
- Restore blades to original sharpness on a fine grit oilstone. Unless nicked or cracked, blades can be resharpened several times.

**Changing Blades**

Raising or replacing cutter blades takes time and patience. Blades must be the same weight and seated at the same height to prevent the cutter head from vibrating. Any deviation can cause the head to run off balance. Blades can fly out, injuring the operator or fellow workers.

Replacing cutter blades involves two steps: removing and installing.

**Removing Blades**

- 1) Disconnect the plane from the power source.
- 2) Turn the plane upside down and secure it in a fixed position.
- 3) Hold the cylinder head stationary by tapping a softwood wedge between the cutter head and the bearing (some tools are equipped with a locking device for this).
- 4) Loosen all the screws and lift out one blade and throat piece.
- 5) Turn the cutter head and repeat this procedure with other blades.
- 6) If necessary, clean parts thoroughly with recommended solvent.

**Installing Blades**

- 1) Replace one throat piece and blade.
- 2) Tighten the two end screws lightly.
- 3) Take a hardwood straight edge and use the outfeed table (back shoe) as a gauge. Raise or lower the blade until both ends are level with the outfeed table at the blade's highest point of revolution.
- 4) Tighten up the remaining screws.
- 5) Set the rest of the blades in the same way.
- 6) Turn the cylinder head and make sure that all blades are the same height.

- 7) Tighten up all the screws.
- 8) Double-check the height of all blades. Tightening can sometimes shift the set.
- 9) Double-check all the screws.
- 10) Turn the tool right side up and plug it in.
- 11) Hold the tool in both hands with the cutter blades facing away from you and switch it on.

**Operation**

- Always disconnect the plane from the power source before adjusting or changing blades or the cutter head.
- Make sure that blades at their highest point of revolution are exactly flush with the outfeed table for safe, efficient operation (Figure 139).

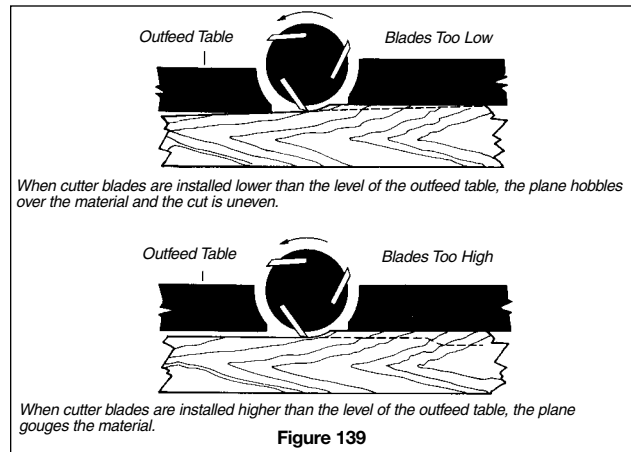

Figure 139

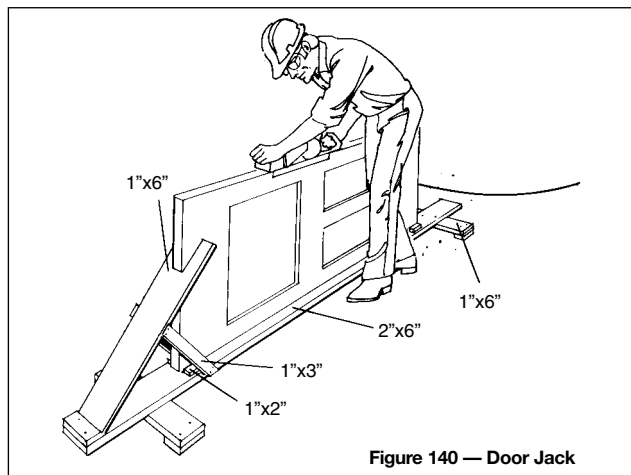

Figure 140 — Door Jack

- Support work securely for safety and accuracy.
- When planing doors and large pieces of plywood, use a jack (Figure 140) to secure material and keep edges clear of dirt and grit.
- When using an electric block plane, clamp or fasten the workpiece whenever possible. Keep your free hand well away from plane and material.
- When using the standard power plane, adjust the edge guide to provide desired guidance.
- Adjust depth of cut to suit the type and width of wood to be planed.
- To start a cut, rest the infeed table (front shoe) firmly on the material with cutter head slightly behind the edge of the material. After finishing a cut, hold both hands on the plane until motor stops.

## Routers

With special guides and bits, the portable electric router can be used to cut dadoes, grooves, mortises, dovetail joints, moldings, and internal or external curves. Carpenters find routers especially useful for mortising stair stringers and recessing hinges and lockplates on doors.

The router motor operates at very high speed (up to 25,000 rpm) and turns clockwise. Components are shown in Figure 141.

**WARNING** The speed and power of the router require that it be operated with both hands.

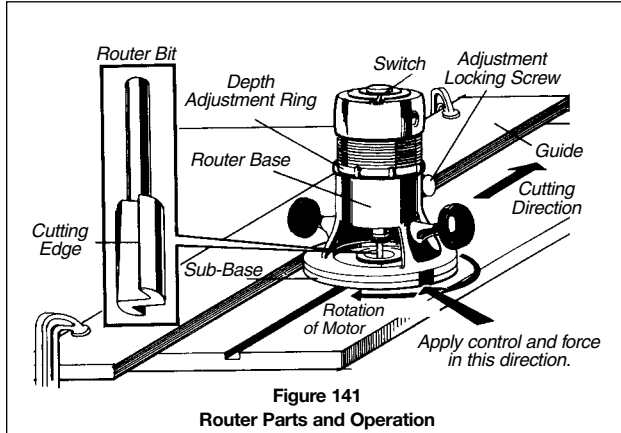

Figure 141  
Router Parts and Operation

When starting a router with a trigger switch in the handle, keep both hands on the tool to absorb the counterclockwise starting torque.

When starting a router with a toggle switch on top of the motor, hold the router firmly with one hand and switch on power with the other, then put both hands on the tool for control and accuracy.

Always wear eye protection. You may also need hearing protection.

### Operation

- Always support and secure the work in a fixed position by mechanical means such as a vise or clamps. Never try to hold the work down with your hand or knee. Never rely on a second person to hold the material. Human grip is no match for the torque and kickback that a router can generate.
- Make sure that the bit is securely mounted in the chuck and the base is tight.
- Set the base on the work, template, or guide and make sure that the bit can rotate freely before switching on the motor.

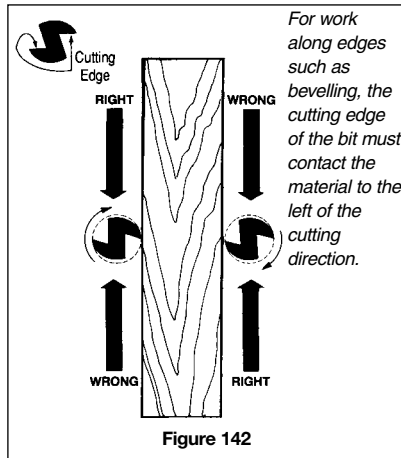

Figure 142

- For work along edges such as bevels and moldings, make sure that the cutting edge of the router bit contacts the material to the **left** of the cutting direction (Figure 142). Otherwise the router will kick back or fly away from you.

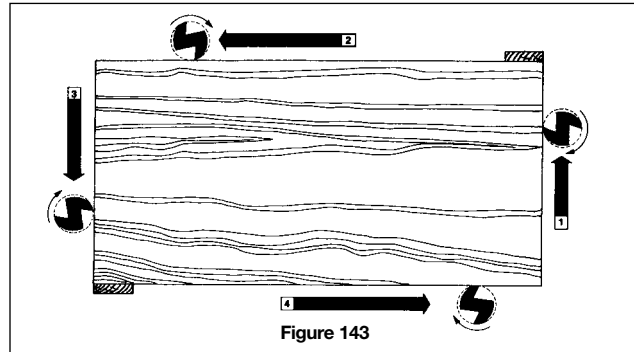

Figure 143

- When routing outside edges, guide the router around the work counterclockwise (Figure 143). Splinters left at corners by routing **across** the grain will be removed by the next pass **with** the grain.
- Feed the router bit into the material at a firm but controllable speed. There is no rule on how fast to cut. When working with softwood, the router can sometimes be moved as fast as it can go. Cutting may be very slow, however, with hardwood, knotty or twisted wood, and larger bits.
- Listen to the motor. When the router is fed into the material too slowly, the motor makes a high-pitched whine. Push too hard and the motor makes a low growling noise. Forcing the tool can cause burnout or kickback. Cutting through knots may cause slowdown or kickback.
- When the type of wood or size of bit requires going slow, make two or more passes to prevent the router from burning out or kicking back.
- If you're not sure about depth of cut or how many passes to make, test the router on a piece of scrap similar to the work.
- When the cut is complete, switch off power and keep both hands on the router until the motor stops. In lifting the tool from the work, avoid contact with the bit.

## 3 POWER TOOLS — SAWS

The saws covered in this chapter are

- circular
- quick-cut
- sabre
- table
- chain
- radial arm
- chop

### Basic Saw Safety

- Wear protective clothing and equipment (see chapter on Personal Protective Equipment). Eye protection is essential.
- Where saws are used in confined spaces or for prolonged periods, wear hearing protection.
- Where ventilation is inadequate, wear a dust mask for protection against dust. Over time, exposure to dust from particle board and other materials may cause respiratory problems.