

Routers

With special guides and bits, the portable electric router can be used to cut dadoes, grooves, mortises, dovetail joints, moldings, and internal or external curves. Carpenters find routers especially useful for mortising stair stringers and recessing hinges and lockplates on doors.

The router motor operates at very high speed (up to 25,000 rpm) and turns clockwise. Components are shown in Figure 141.

WARNING The speed and power of the router require that it be operated with both hands.

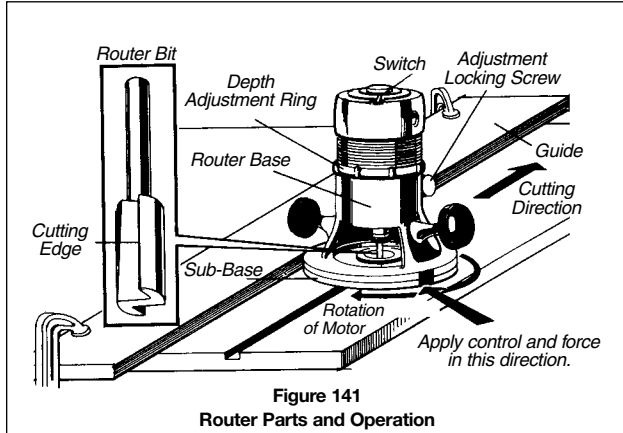

When starting a router with a trigger switch in the handle, keep both hands on the tool to absorb the counterclockwise starting torque.

When starting a router with a toggle switch on top of the motor, hold the router firmly with one hand and switch on power with the other, then put both hands on the tool for control and accuracy.

Always wear eye protection. You may also need hearing protection.

Operation

- Always support and secure the work in a fixed position by mechanical means such as a vise or clamps. Never try to hold the work down with your hand or knee. Never rely on a second person to hold the material. Human grip is no match for the torque and kickback that a router can generate.
- Make sure that the bit is securely mounted in the chuck and the base is tight.
- Set the base on the work, template, or guide and make sure that the bit can rotate freely before switching on the motor.

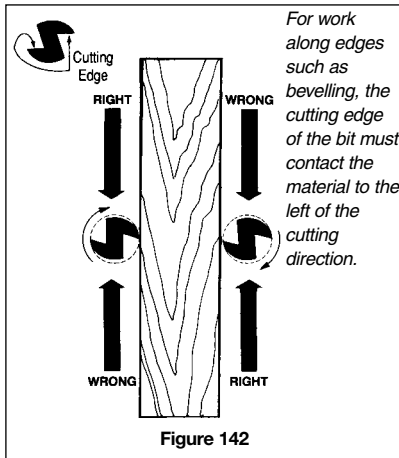

- For work along edges such as bevels and moldings, make sure that the cutting edge of the router bit contacts the material to the **left** of the cutting direction (Figure 142). Otherwise the router will kick back or fly away from you.

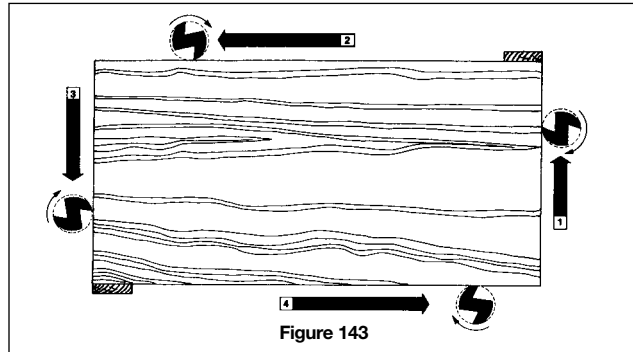

- When routing outside edges, guide the router around the work counterclockwise (Figure 143). Splinters left at corners by routing **across** the grain will be removed by the next pass **with** the grain.
- Feed the router bit into the material at a firm but controllable speed. There is no rule on how fast to cut. When working with softwood, the router can sometimes be moved as fast as it can go. Cutting may be very slow, however, with hardwood, knotty or twisted wood, and larger bits.
- Listen to the motor. When the router is fed into the material too slowly, the motor makes a high-pitched whine. Push too hard and the motor makes a low growling noise. Forcing the tool can cause burnout or kickback. Cutting through knots may cause slowdown or kickback.
- When the type of wood or size of bit requires going slow, make two or more passes to prevent the router from burning out or kicking back.
- If you're not sure about depth of cut or how many passes to make, test the router on a piece of scrap similar to the work.
- When the cut is complete, switch off power and keep both hands on the router until the motor stops. In lifting the tool from the work, avoid contact with the bit.

3 POWER TOOLS — SAWS

The saws covered in this chapter are

- circular
- quick-cut
- sabre
- table
- chain
- radial arm
- chop

Basic Saw Safety

- Wear protective clothing and equipment (see chapter on Personal Protective Equipment). Eye protection is essential.
- Where saws are used in confined spaces or for prolonged periods, wear hearing protection.
- Where ventilation is inadequate, wear a dust mask for protection against dust. Over time, exposure to dust from particle board and other materials may cause respiratory problems.

- With electric saws operated outdoors or in wet locations, you must use a ground fault circuit interrupter.
- Never wear loose clothing, neck chains, scarves, or anything else that can get caught in the saw.
- Leave safety devices in place and intact on the saw. Never remove, modify, or defeat guards. Keep your free hand away from blade (Figure 144).

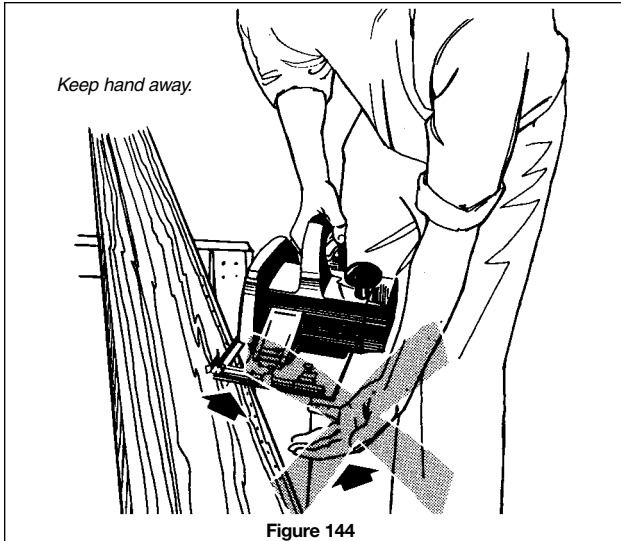
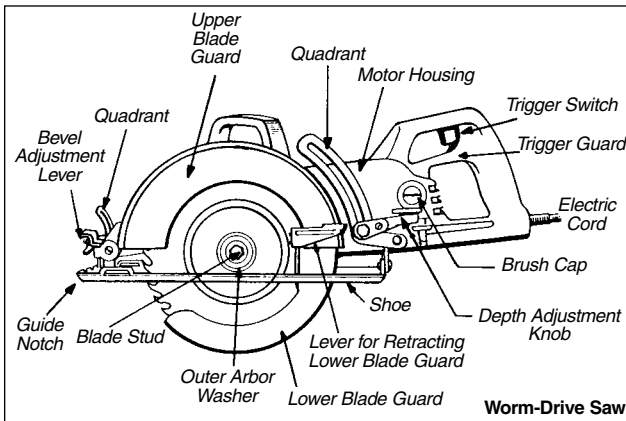
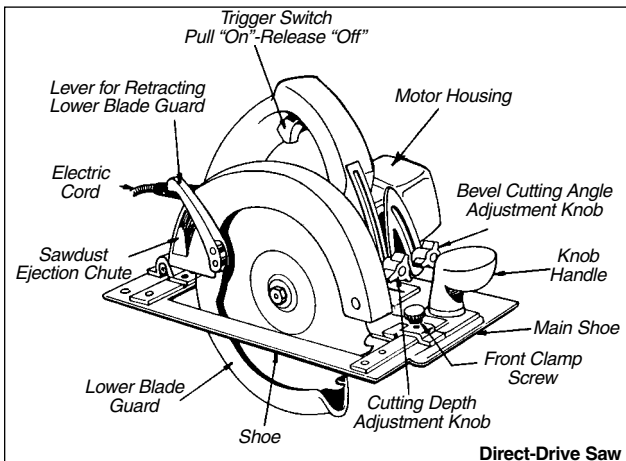

Figure 144

- Always change and adjust blades with the power OFF. Disconnect electric saws from the power source before making changes or adjustments.



Worm-Drive Saw



Direct-Drive Saw

Circular Handsaws

The two models most often used on construction sites are illustrated. The main difference between the two lies in the drive action. The worm-drive saw has gears arranged so that the blade runs parallel to the motor shaft. The direct-drive saw has the blade at a right angle to the motor shaft.

The worm-drive saw periodically requires special gear oil to keep the inner gears lubricated. This requirement is usually eliminated in the direct-drive saw, which has sealed bearings and gears.

Both saws must be inspected regularly for defects, and operated and maintained in accordance with manufacturers' recommendations.

Check for

- | | |
|----------------------------|-----------------------------|
| - damaged cord | - loose blade |
| - faulty guards | - defective trigger |
| - chipped or missing teeth | - cracked or damaged casing |

Safety Features

Sawdust Ejection Chute

This feature prevents sawdust from collecting in front of the saw and obscuring the cutting line. The operator can continue cutting without having to stop the saw and clear away sawdust.

Clutch

Some worm-drive saws are equipped with a clutch to prevent kickback. Kickback occurs when a saw meets resistance and violently backs out of the work. The clutch action allows the blade shaft to continue turning when the blade meets resistance. The blade stud and friction washer can be adjusted to provide kickback protection for cutting different materials. Check friction washers for wear.

Brake

An electric brake on some circular saws stops the blade from coasting once the switch is released. This greatly reduces the danger of accidental contact.

Trigger Safety

On some light-duty saws a latch prevents the operator from accidentally starting the motor. The trigger on the inside of the handle cannot be pressed without first pressing a latch on the outside of the handle. On heavy-duty saws a bar under the trigger switch helps to prevent accidental starting.

Blades

Blades should be sharpened or changed frequently to prolong saw life, increase production, and reduce operator fatigue. The teeth on a dull or abused blade will turn blue from overheating. Cutting will create a burning smell. Such blades should be discarded or reconditioned.

Before changing or adjusting blades, disconnect the saw from the power source.

Take care to choose the right blade for the job. Blades are available in a variety of styles and tooth sizes.

Combination blades (rip and crosscut) are the most widely used.

Ensure that arbor diameter and blade diameter are right for the saw.

Because all lumber is not new, make sure it is clean and free of nails, concrete, and other foreign objects. This precaution not only prolongs blade life but may also prevent serious injury.

Take special care to ensure that blades are installed in the proper rotational direction (Figure 145). Remember that electrical circular handsaws cut with an upward motion. The teeth visible between the

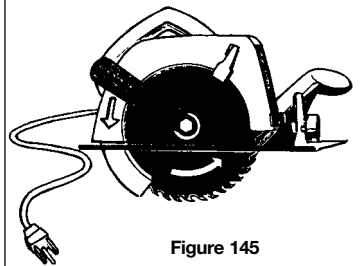

Figure 145

upper and lower guard should be pointing toward the front of the saw. Most models have a directional arrow on both blade and guard to serve as a guide.

Blade Guards

Never operate an electric saw with the lower guard tied or wedged open. The saw may kick back and cut you, or another worker may pick up the saw and – not knowing that the guard is pinned back – get hurt.

Accidents have also occurred when the operator forgot that the blade was exposed and put the saw on the floor. The blade, still in motion, forced the saw to move, cutting anything in its path.

Make sure that the lower guard returns to its proper position after a cut. Never operate a saw with a defective guard-retracting lever.

On most saws the lower guard is spring-loaded and correct tension in the spring will automatically close the guard. However, a spring weakened by use and wear can allow the guard to remain open after cutting. This creates a potential for injury if the operator inadvertently rests a still turning blade against his leg after finishing a cut. Always maintain complete control of the saw until the blade stops turning. The guard may also be slow to return after 45° cuts.

Choosing the Proper Blade

For safety, saw operators must understand the different designs and uses of blades (Figure 146). Blades unsuited for the job can be as hazardous as dull blades. For instance, a saw fitted with the wrong blade for the job can run hot so quickly that blade tension changes and creates a wobbly motion. The saw may kick back dangerously before the operator can switch it off.

Resharpener blades can be substantially reduced in diameter – for instance, from nine to eight inches. Make sure that the blade diameter and arbor diameter are right for the saw.

Carbide-Tipped Blades – Take special care not to strike metal when using a carbide-tipped blade. The carbide tips can come loose and fly off, ruining the blade and injuring the operator. Inspect the blade regularly for cracked or missing tips.

Crosscut Blade —

The bevelled sharp-pointed teeth are designed to cut the crossgrain in wood. Size and bevel of the teeth are important factors in cutting different woods.

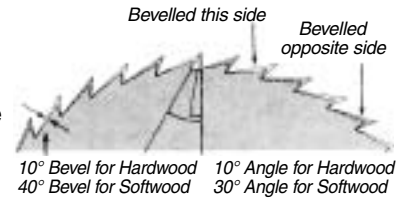

Softwood requires bigger teeth to carry off the sawdust. Hardwood requires fine teeth with many cutting edges. Note the different angles and edges needed for cutting hardwood and softwood.

Ripsaw Blade —

The flat sharp teeth are designed to cut the long grain in wood. They are neither bevelled nor needle-pointed. Needle-pointed teeth would get clogged

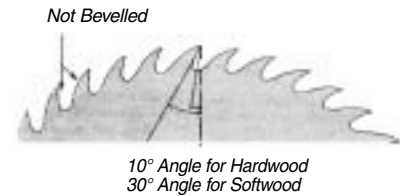

and the blade would become overheated. Never use a ripsaw blade for crosscutting or for cutting plywood. The material can jam and overheat the blade or splinter in long slivers that may seriously injure the operator.

Combination Blade

This blade combines features of the crosscut and ripsaw blades. It can be used for crosscutting and ripping, or for cutting plywood. Carpenters on construction sites prefer the combination blade for rough woodworking such as stud walls and formwork because they don't have to change blades. The teeth are alternately bevelled and have a straight front. The heel of each tooth is not lower than the heel of the tooth on either side of it.

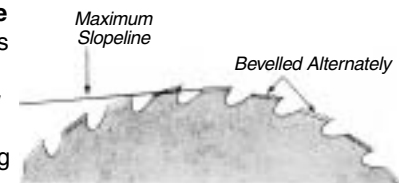

Standard Combination or Mitre Blade

This is mainly used by trim carpenters. It includes teeth for crosscutting, raker teeth for ripping, and deep gullets for carrying off sawdust. The blade can be used for cutting both hardwood and softwood and for mitring.

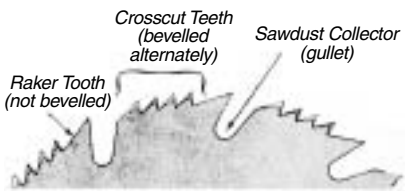

Figure 146

Changing, Adjusting, and Setting Blades

When changing blades, take the following precautions.

1. Disconnect the saw from the power source.
2. Place the saw blade on a piece of scrap lumber and press down until the teeth dig into the wood (Figure 147). This prevents the blade from turning when the locking nut is loosened or tightened. Some machines are provided with a mechanical locking device.
3. Make sure that keys and adjusting wrenches are removed before operating the saw.

Proper adjustment of cutting depth keeps blade friction to a minimum, removes sawdust from the cut, and results in cool cutting.

The blade should project the depth of one full tooth below the material to be cut (Figure 148).

When using carbide-tipped blades or mitre blades let only half a tooth project below the material. If the blade is to run freely in the kerf (saw cut), teeth must be set properly, that is, bent alternately (Figure 149). The setting of teeth differs from one type of blade to another. Finer-toothed blades require less set than rougher-toothed blades. Generally, teeth should be alternately bent 1/2 times the thickness of the blade.

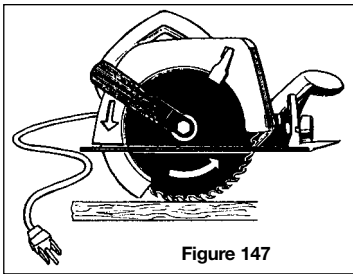

Figure 147

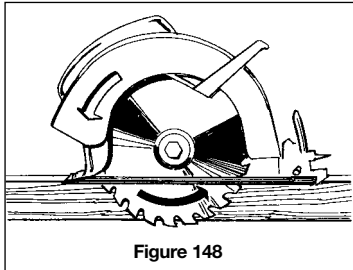

Figure 148

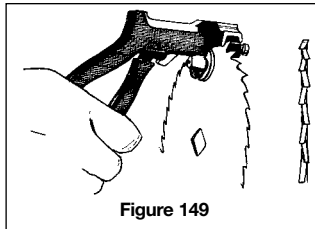

Figure 149

Sharp blades with properly set teeth will reduce the chance of wood binding. They will also prevent the saw from overheating and kicking back.

Cutting

Place the material to be cut on a rigid support such as a bench or two or more sawhorses. Make sure that the blade will clear the supporting surface and the power cord. The wide part of the saw shoe should rest on the supported side of the cut if possible.

Plywood is one of the most difficult materials to cut with any type of saw. The overall size of the sheet and the internal stresses released by cutting are the main causes of difficulty. Large sheets should be supported in at least three places, with one support next to the cut.

Short pieces of material should not be held by hand. Use some form of clamping to hold the material down when cutting it (Figure 150).

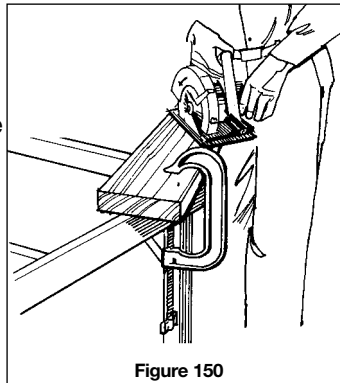

Figure 150

NEVER use your foot or leg to support the material being cut. Too many operators have been seriously injured by this careless act.

The material to be cut should be placed with its good side down, if possible. Because the blade cuts upward into the material, any splintering will be on the side which is uppermost.

Use just enough force to let the blade cut without labouring. Hardness and toughness can vary in the same piece of material, and a knotty or wet section can put a heavier load on the saw. When this happens, reduce pressure to keep the speed of the blade constant. Forcing the saw beyond its capacity will result in rough and inaccurate cuts. It will also overheat the motor and the saw blade.

Take the saw to the material. Never place the saw in a fixed, upside-down position and feed material into it. Use a table saw instead.

If the cut gets off line, don't force the saw back onto line. Withdraw the blade and either start over on the same line or begin on a new line.

If cutting right-handed, keep the cord on that side of your body. Stand to one side of the cutting line. **Never reach under the material being cut.**

Always keep your free hand on the long side of the lumber and clear of the saw. Maintain a firm, well-balanced stance, particularly when working on uneven footing.

Plywood, wet lumber, and lumber with a twisted grain tend to tighten around a blade and may cause kickback. Kickback occurs when an electric saw stalls suddenly and jerks back toward the operator. The momentarily exposed blade may cause severe injury.

Use extreme caution and don't relax your grip on the saw.

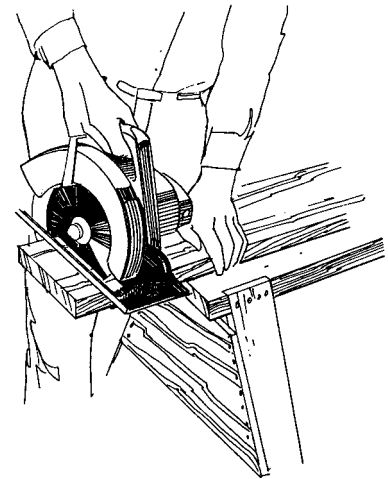

Pocket Cutting

1. Tilt saw forward.
2. Rest front of shoe on wood.
3. Retract lower guard.
4. Lower saw until front teeth almost touch wood.
5. Release guard to rest on wood.
6. Switch on the saw.

7. Keep the saw tilted forward and push it down and forward with even pressure, gradually lowering it until shoe rests flat on wood.
8. Follow these steps with extreme care.

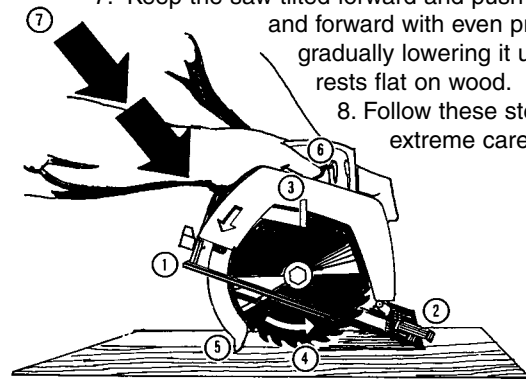

Sabre Saws

The sabre saw, or portable jigsaw (Figure 151), is designed for cutting external or internal contours. The saw should not be used for continuous or heavy cutting that can be done more safely and efficiently with a circular saw.

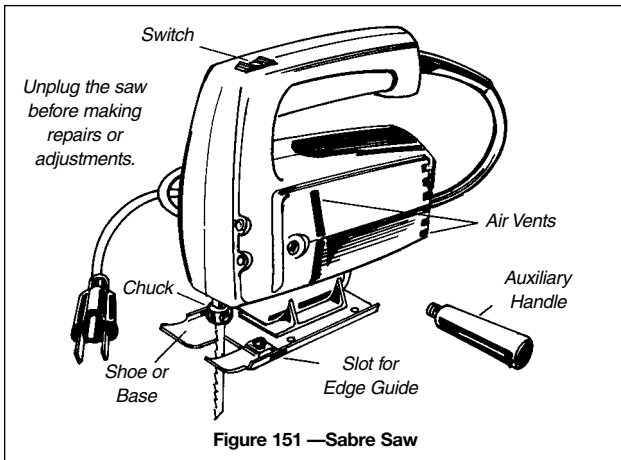

The stroke of the sabre saw is about 1/2 inch for the light-duty model and about 3/4 inch for the heavy duty model. The one-speed saw operates at approximately 2,500 strokes per minute. The variable-speed saw can operate from one to 2,500 strokes per minute.

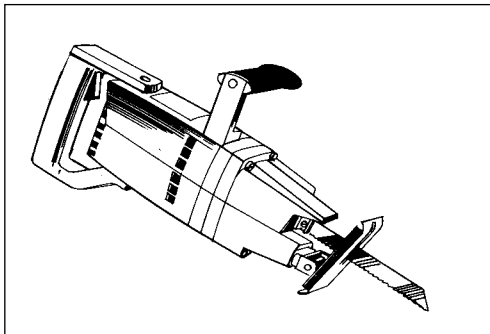
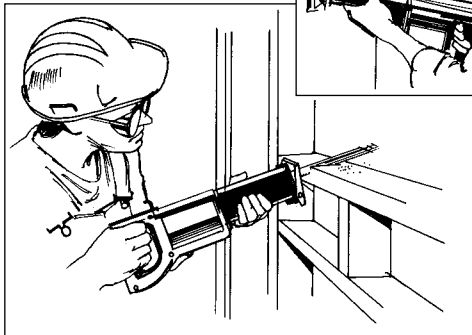

Figure 152
Reciprocating Saw

Use caution when cutting through walls. Beware of electrical wiring and other services in or behind the wall.



The reciprocating saw (Figure 152) is a heavier type of sabre saw with a larger and more rugged blade. The tool is often used by drywall and acoustical workers to cut holes in ceilings and walls. Equipped with a small swivel

base, the saw can be used in corners or free-hand in hard-to-reach places. The reciprocating saw must be held with both hands to absorb vibration and to avoid accidental contact.

Eye protection is a must. You may also need respiratory protection.

Choosing the Proper Blade

Various blades, ranging from 7 to 32 teeth per inch, are available for cutting different materials. For the rough cutting of stock such as softwood and composition board, a blade with 7 teeth per inch will cut the fastest. For all-round work with most types of wood, a blade with 10 teeth per inch is satisfactory.

Cutting

The sabre saw cuts on the upstroke. Splintering will therefore occur on the top side of the material being cut. Consequently, the good side should be facing down. The degree of splintering depends on the type of blade, the vibration of the material, and the feed of the saw.

To avoid vibration, the material should be clamped or otherwise secured and supported as close to the cutting line as possible. If the material vibrates excessively or shifts during cutting, the saw can run out of control, damaging the blade and injuring the operator.

- Before starting a cut make sure that the saw will not contact clamps, the vise, workbench, or other support.
- Never reach under the material being cut.
- Never lay down the saw until the motor has stopped.
- Do not try to cut curves so tight that the blade will twist and break.
- Always hold the base or shoe of the saw in firm contact with the material being cut.

WARNING When sawing into floors, ceiling, or walls, always check for plumbing and wiring.

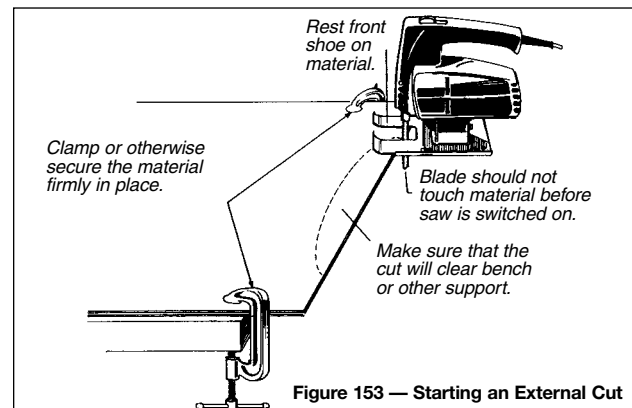

External Cut (Figure 153)

To start an external cut (from the outside in), place the front of the shoe on the material. Make sure that the blade is not in contact with the material or the saw will stall when the motor starts.

Hold the saw firmly and switch it on. Feed the blade slowly into the material and maintain an even pressure. When the cut is complete, do not lay down the saw until the motor has stopped.

Inside Cuts (Figure 154)

To start an inside cut (pocket cut), first drill a lead hole slightly larger than the saw blade. With the saw switched off, insert the blade into the hole until the shoe rests firmly on the material. Do not let the blade touch the material until the saw has been switched on.

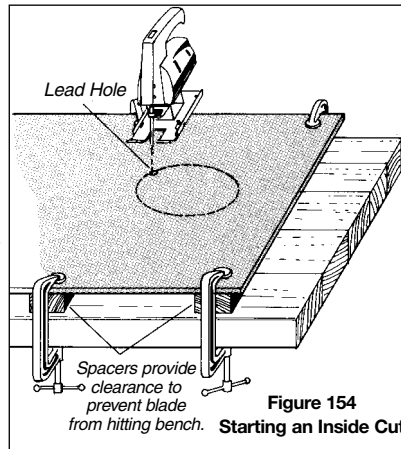

It is possible to start an inside cut

without drilling a lead hole first — but only when it's absolutely necessary. To do this, rest the front edge of the shoe on the material with the saw tipped backward. Keep the blade out of contact with the material.

Switch on the saw and slowly feed the blade into the material while lowering the back edge of the shoe. When the shoe rests flat on the material and the blade is completely through, proceed with the cut. Any deviation from this procedure can cause the blade to break and injure the operator or workers nearby.

Never try to insert a blade into, or withdraw a blade from, a cut or a lead hole while the motor is running.

Never reach under the material being cut.

Chainsaws

Each year in Ontario, construction workers are injured while using chainsaws. Generally the injuries result from two types of accidents:

- 1) the operator makes accidental contact with the revolving chain
- 2) the operator is struck by the object being cut, usually a tree or heavy limb.

Many of these injuries are serious.

While the chainsaw is relatively easy to operate, it can be lethal. As with all high-speed cutting tools, it demands the full attention of even the trained and experienced operator.

Requirements

Chainsaws can be powered by electric motors (Figure 155) or gasoline engines (Figure 156).

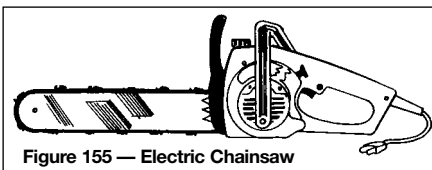

Both saws are designed to provide fast cutting action with a minimum of binding in the cut, even though wood may be sap-filled or wet. Both afford about the same performance in terms of horsepower and they are equipped with similar controls and safety devices.

Regulations require that chainsaws used in construction must be equipped with a chain brake. Make sure that the

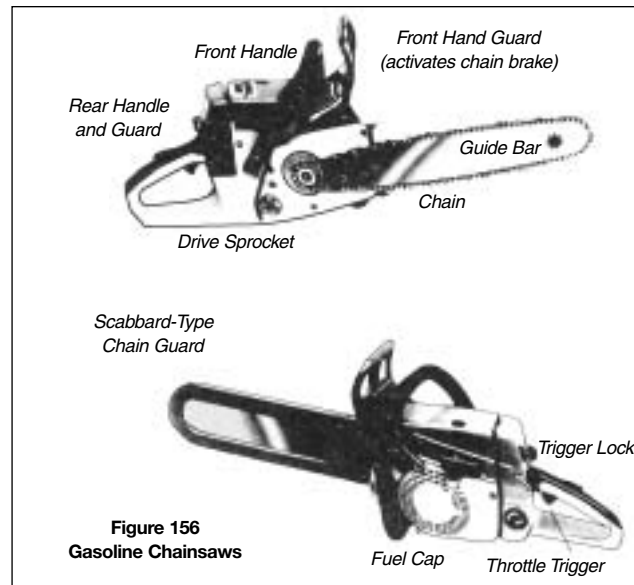

saw is equipped with a chain brake mechanism, and not simply a hand guard, which is similar in appearance.

Regulations require that chainsaws used in construction must be equipped with “anti-kickback” chains. Called safety chains (Figure 157) by the manufacturers, these chains incorporate design features intended to minimize kickback while maintaining cutting performance.

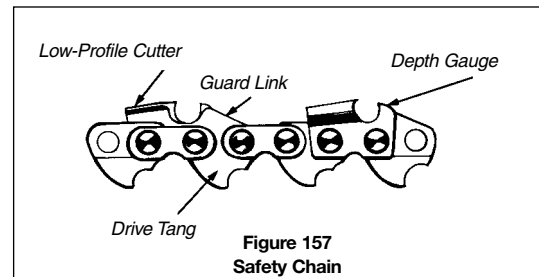
**Protective Clothing and Equipment**

- Eye protection in the form of plastic goggles is recommended. A faceshield attached to the hard hat will not provide the total eye protection of close-fitting goggles.
- Leather gloves offer a good grip on the saw, protect the hands, and absorb some vibration. Gloves with ballistic nylon reinforcement on the back of the hand are recommended.
- Since most chainsaws develop a high decibel rating (between 95 and 115 dBA depending on age and condition), adequate hearing protection must be worn, especially during prolonged exposure.
- Trousers or chaps with sewn-in ballistic nylon pads provide excellent protection, particularly for the worker who regularly uses a chainsaw.

Kickback

Kickback describes the violent motion of the saw that can result when a rotating chain is unexpectedly interrupted. The cutting chain's forward movement is halted and energy is transferred to the saw, throwing it back from the cut toward the operator.

The most common and probably most violent kickback occurs when contact is made in the “kickback zone” (Figure 158).

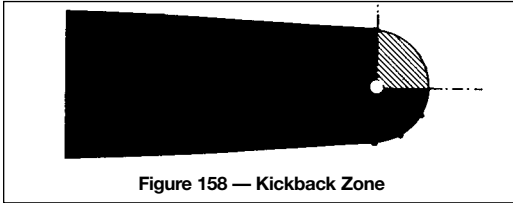

Figure 158 — Kickback Zone

Contact in this zone makes the chain bunch up and try to climb out of the track. This most often happens when the saw tip makes contact with something beyond the cutting area such as a tree branch, log, or the ground.

To minimize the risk of kickback

- use a low-profile safety chain
- run the saw at high rpm when cutting
- sharpen the chain to correct specifications
- set depth gauges to manufacturers' settings
- maintain correct chain tension
- hold the saw securely with both hands
- don't operate the saw when you are tired
- know where the bar tip is at all times
- don't allow the cut to close on the saw
- make sure the chain brake is functioning.

Starting

When starting, hold the saw firmly on the ground or other level support with the chain pointing away from your body and nearby obstructions. Use a quick, sharp motion on the starter pull (Figure 159). Never “drop start” the saw. This leaves only one hand to control a running saw and has resulted in leg cuts. Use the proper grip (Figure 160).

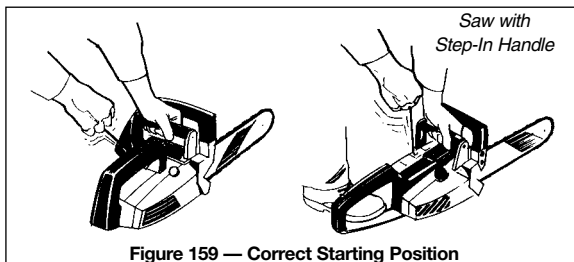

Figure 159 — Correct Starting Position

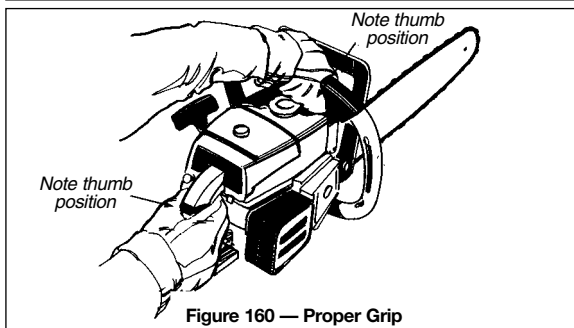
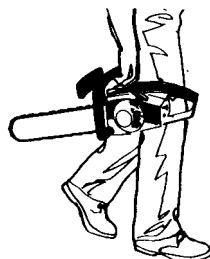

Figure 160 — Proper Grip

Before moving from place to place, shut off the saw and walk with the guide bar pointed backwards. A trip or a stumble with a running saw can cause serious injury.



Site Hazards

- Take extra care when making pocket cuts (Figure 161). Start the cut with the underside of the chain tip, then work the saw down and back to avoid contact with the kickback zone. Consider an alternative such as a sabre saw.

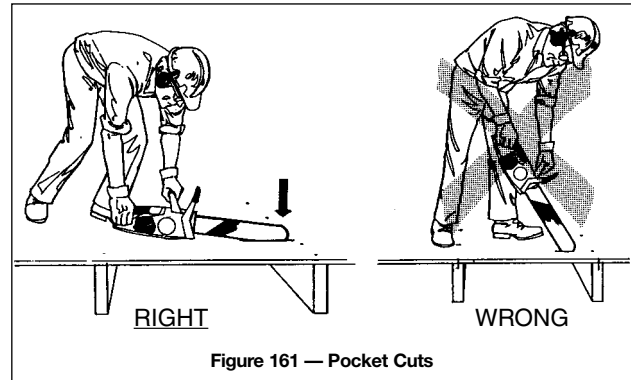

Figure 161 — Pocket Cuts

- Be particularly careful to avoid contact with nails, piping, and other metallic objects. This is especially important when making a pocket cut through framing lumber such as a subfloor or when cutting used lumber such as trench shoring, lagging, or blocking timbers.
- Use chainsaws to cut wood only. They are not designed to cut other materials.
- When using a chainsaw to trim rafter ends, take the following steps to avoid injury:
 - Cut down from the top of the rafter. Don't cut from underneath.
 - Use a harness, lanyard, and lifeline to prevent falls or work from a secure scaffold at eaves level.
 - The extension cord on an electric chainsaw should be secured on the roof above the operator with enough working slack. This will prevent the weight of a long cord from pulling the operator off balance.
 - Keep both hands firmly on the saw.

Maintenance

Well-maintained cutting components are essential for safe operation. A dull or improperly filed chain will increase the risk of kickback.

- Inspect and maintain your saw according to the manufacturer's recommendations regarding chain tension, wear, replacement, etc. Check for excessive chain wear and replace chain when required. Worn chains may break!
- Select the proper size files for sharpening the chain. Two files are necessary:
 - 1) a flat file for adjusting depth gauge
 - 2) a round file of uniform diameter for sharpening cutters and maintaining drive links.
- You must choose the correct round file for your chain to avoid damaging the cutters. Consult the owner's manual or the supplier to be sure of file size.
- A round file used in combination with a file holder or, better yet, a precision filing guide will give the best results (Figure 162).

Adjusting Chain Tension

- Follow the manufacturer's instructions on chain tension.

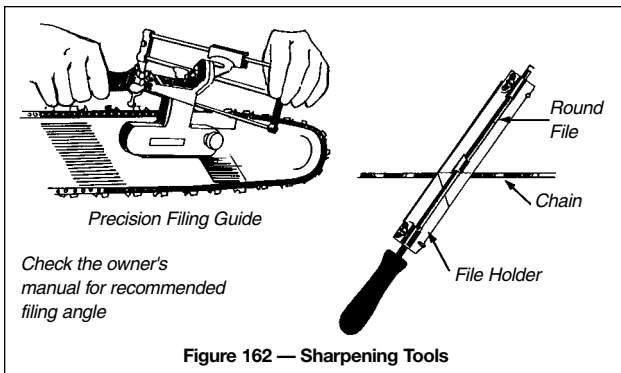

Figure 162 — Sharpening Tools

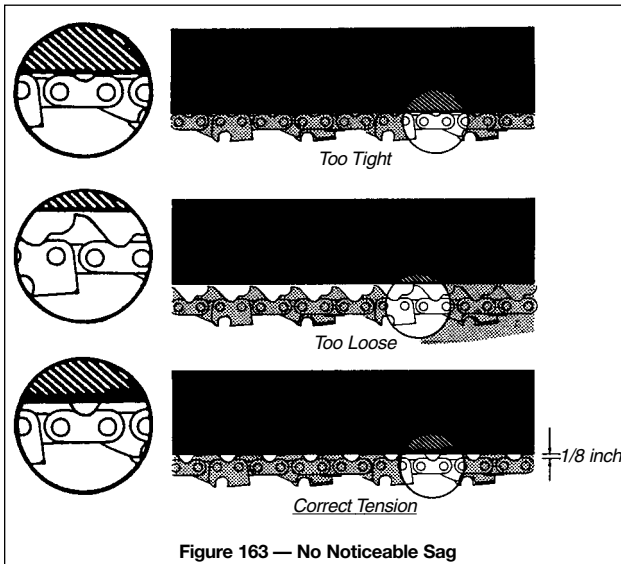
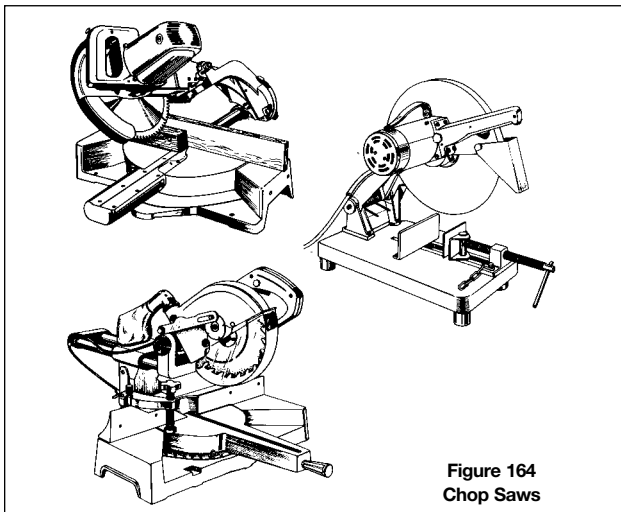

Figure 163 — No Noticeable Sag

- In general, the chain should move easily around the bar by hand without showing noticeable sag at the bottom (Figure 163).
- Be generous with chain lubricating oil. It is almost impossible to use too much. Most late model saws have automatic oilers. **But operators must still remember to fill the chain-oil reservoir.**

Chop Saws

Increasingly, carpenters and other trades are using chop saws to cut various materials (Figure 164). These portable saws offer quick, efficient, and economical cutting.

Figure 164
Chop Saws

Unfortunately, like all power equipment, chop saws pose serious hazards for the unwary or untrained operator. Follow **Basic Saw Safety** (page 221) and **Safety Basics** (page 217) as for other power saws.

Most of these saws are equipped with abrasive wheels for quick cutting through metal studs and other material.

- Select the proper abrasive cutting wheel for the material being cut. For metals, use aluminum oxide. For masonry, stone, and concrete, use silica carborundum.
- The rpm of the saw should not exceed the recommended rpm printed on the blade label.
- The centre hole on the blade must fit the mandril and be snugly fastened in place with the proper washer and lock nut.

Warning A loose or off-centre blade can shatter in use.

- Position material to be cut at 90 degrees to the blade. Support the other end to prevent the blade from binding.
- Do not rush cutting. Let the wheel cut without burning or jamming.
- When cutting is complete, let the blade stop before moving material.
- Maintain the saw in good repair with the blade guard in place and working smoothly. Tighten any loose parts and replace any broken or damaged ones.
- Don't try to adjust for length on downward cutting motion. Your hand could slide into the blade while it is spinning.
- With some large chop saws (Figure 165), additional precautions are required because of the tremendous torque the saws can develop.
- Beware of sparks landing on combustible material.

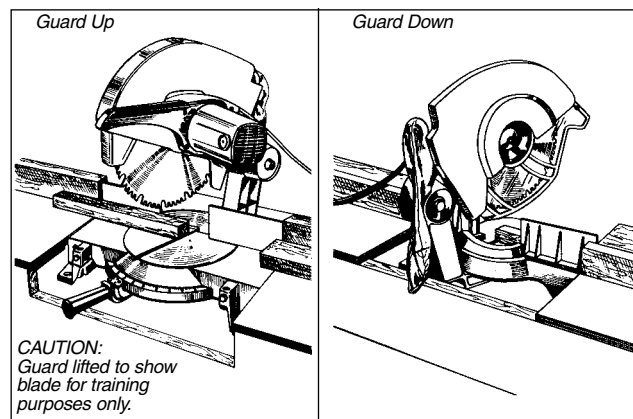

Figure 165 — Some large chop saws may require additional precautions.

Quick-Cut Saws

Hand-held portable circular cut-off saws are commonly known as "quick-cut saws" in construction (Figure 166). They are widely used for cutting concrete, masonry products, sheet metal products (both steel and aluminum), and light steel sections such as angles and channels.

Hazards

Quick-cut saws are high-powered compared to similar tools. Hazards include high-speed blade rotation, blade exposure during operation, and exhaust from the internal combustion engine (the usual power source).

The saws also create clouds of dust when dry-cutting masonry and showers of hot sparks when cutting metal products, especially steel.

These hazards can result in cuts, kickbacks, exposure to carbon monoxide fumes, exposure to dusts (silica from concrete and masonry products in particular), burns, flying particles hitting the eye, and other injuries from flying material when work is not secured for cutting or when blades fly apart.

These hazards can be controlled by

- operators trained to use quick-cut saws properly and to wear the right protective equipment such as eye, hearing, and respiratory protection as well as face shields and gloves
- saws kept in good working condition, equipped with proper blades or disks, and used with all guards in place
- work secured to keep it from shifting during cutting
- caution around sharp edges left by cuts.

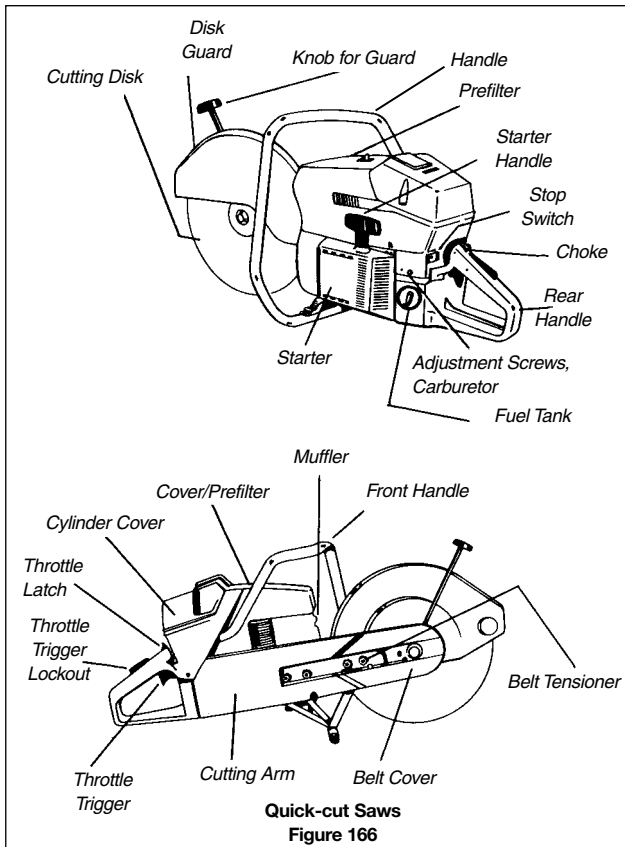

Training

Operators should be instructed in the care, maintenance, and operation of quick-cut saws. They should read the operating manual, review the major points, and receive both oral and written instruction.

The operating manual should be available on the job, not only for instruction but for ready reference if something goes wrong with the saw or it must be used for work outside the operator's experience.

Time spent on instruction will reduce accidents and injuries as well as prolong the service life of the saw.

As a minimum the operator should be instructed in

- care of the saw
- installing disks and blades
- mixing fuel and fueling the saw
- starting the saw
- supporting and securing work to be cut
- proper cutting stance and grip
- proper cutting techniques for different material
- respiratory protection against dusts
- how to inspect and store abrasive disks.

Care

Quick-cut saws must be serviced and maintained in accordance with the manufacturers' instructions. Replacement parts should be those recommended by the manufacturer.

Cracked, broken, or worn parts should be replaced before the saw is used again. Guards and air-intakes should be cleaned regularly and often. Abrasive disks should be checked before installation and frequently during use. Correct any excessive blade vibration before trying to make a cut.

In confined areas, make sure that ventilation is adequate. Gasoline-driven saws release carbon monoxide gas — odourless, colourless, and highly toxic.

Starting

Most of the following procedures are for gasoline-powered quick-cut saws — the type most commonly used in construction.

- Use caution when preparing the oil/gasoline mixture and when fuelling the saw. No smoking or ignition sources should be allowed in the area where fuel is mixed or tanks are filled.
- Fill the tank outdoors in a well-ventilated space at least 3 metres from the area where the saw will be used. Spilled fuel should be wiped off the saw.
- Avoid fuelling the saw on or near formwork. Gasoline spills are a fire hazard. Use a funnel to avoid spills.
- Do not overfill the saw or run it without securing the fuel tank cap. Gasoline seeping from the tank can saturate your clothing and be ignited by sparks thrown off from metal cutting. The only cap to use is one supplied by the manufacturer.
- Check the saw for leaks. Sometimes vibration makes gas lines leak.
- Start the saw in an area clear of people and obstacles. Under no circumstances should anyone be standing in front of the saw as it starts or while it's running.
- Put the saw on a smooth hard surface for starting. The guard should be properly set for the type of cut beforehand.
- Assume a solid well-balanced stance. Do not wrap the starter cord around your hand — this can cause injury.
- Set one foot on the rear handle, put one hand on the top handle to lift the blade off the surface, and use the other hand to pull the starter cord (Figure 167).

Warning: Always shut off saw before fuelling.
Keep fuel container well clear of work area.



Figure 167 — Starting Position

- Once the saw is running, release the throttle and make sure the engine drops to idle without the disk or blade moving.
- Run the engine at full throttle and let the disk or blade run freely to make sure it turns on the arbor without wobbling or vibrating.

Support

One of the major hazards with quick-cut saws is failure to support and secure the work to be cut.

The saw is powerful enough to throw material around unless it is securely held and supported. Standing on material to hold it down is **not** recommended.

For repeated cuts of masonry or metal pieces, a jig is ideal for efficiency and safety. The jig should be designed and built to hold material in place after measurement without further manual contact (Figure 168).

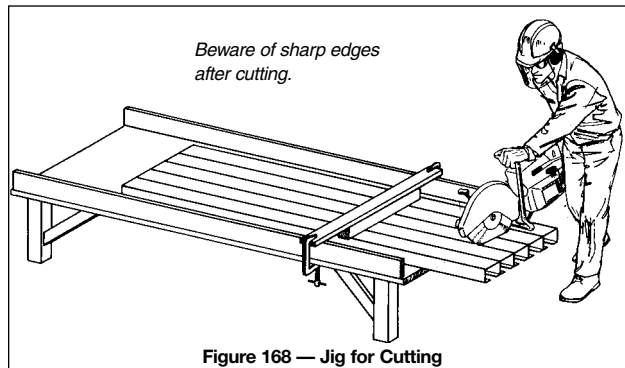
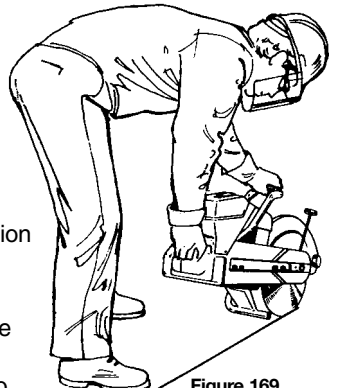

Figure 168 — Jig for Cutting

Stance and Grip

The quick-cut saw is a heavy, powerful tool that must be held by hand. Operators need a secure stance with legs apart for balance and support. The saw should be held at a comfortable, balanced location in front of the operator.

Grip the saw firmly with one hand on each handle. Hold your forward arm straight to keep the saw from kicking back or climbing out of the cut (Figure 169).

Figure 169
Cutting Stance and Grip

Cutting

Although skill in handling the quick-cut saw can only be learned through practice, some safety considerations and operating techniques must always be kept in mind, even by the most experienced operators.

Work should be supported so that the disk or blade will not bind in the cut. Support heavy materials on both sides of the cut so the cut piece will not drop or roll onto the operator's foot. Light materials can generally be allowed to fall. In all cases the cut should be as close as possible to the supporting surface (Figure 170).

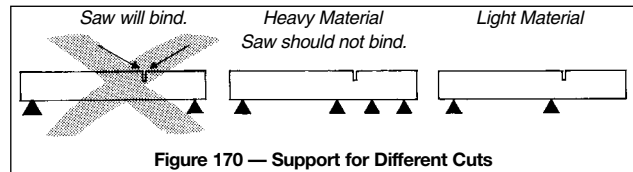

Figure 170 — Support for Different Cuts

Kickback and Pull-In

Kickback can happen extremely fast and with tremendous power. If the segment of the disk or blade shown in Figure 171 contacts the work, the disk or blade starts to climb out of the cut and can throw the saw up and back toward the operator with great force.

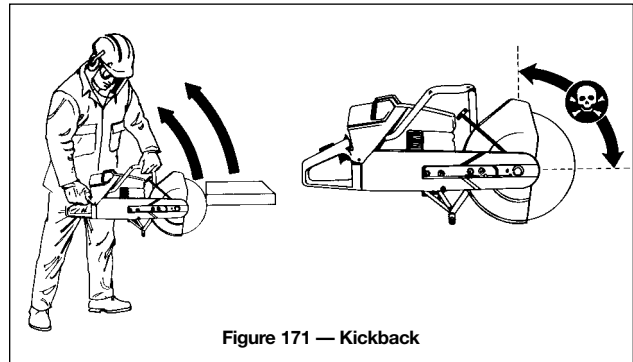

Figure 171 — Kickback

For cutting, keep the throttle wide open. Ease the blade down onto the cut line. Don't drop or jam the blade down hard. Move the saw slowly back and forth in the cut.

Hold the saw so that disk or blade is at right angles to the work and use only the cutting edge of the disk or blade (Figure 172). Never use the side of a disk for cutting. A worn disk will almost certainly shatter and may cause severe injury.

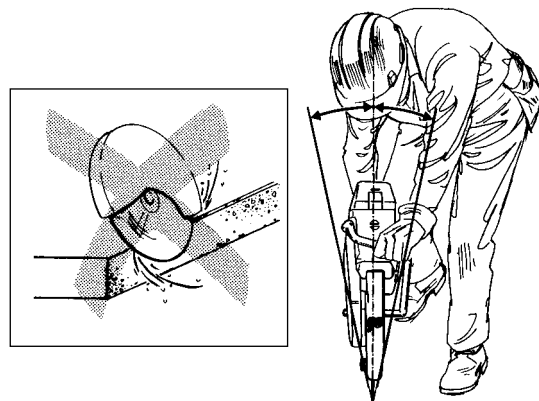

Figure 172 — Saw at Right Angles to Material

Beware of blade run-on. The blade may continue to rotate after the cut and run away with a saw set down too soon.

Don't force the saw to one side of the cut. This will bend the disk or blade and cause it to bind, possibly to break.

Water cooling is recommended for cutting masonry materials. It prolongs disk life and reduces dust exposure.

Keep pressure on the saw reasonably light. Although more pressure may be necessary for hard materials, it can cause an abrasive disk to chip or go "out of round." This in turn will make the saw vibrate. If lowering the feed pressure does not stop vibration, replace the disk.

Don't carry the saw any distance with the engine running. Stop the engine and carry the saw with the muffler away from you.

To avoid kickback, take the following steps:

- Secure and support the material at a comfortable position for cutting. Make sure that material will not move, shift, or pinch the blade or disk during cutting.
- Keep steady balance and solid footing when making a cut.
- Do not support the work on or against your foot or leg.
- Use both hands to control the saw. Maintain a firm grip with thumb and fingers encircling the handles.
- Never let the upper quarter segment of blade or disk contact the material.
- Run the saw at full throttle.
- Do not cut above chest height.
- When reentering a cut, do so without causing blade or disk to pinch.

Pull-in occurs when the lower part of the disk or blade is stopped suddenly – for instance, by a cut closing up and binding. The saw pitches forward and can pull the operator off balance.

Protective Equipment

In addition to the standard equipment mandatory on construction sites, operators of quick-cut saws should wear snug-fitting clothing, hearing protection, eye and face protection, and heavy-duty leather gloves (Figure 173).

The dry cutting of masonry or concrete products calls for respiratory protection as well. See the chapter on Personal Protective Equipment.

For general dust hazards, a half-mask cartridge respirator with NIOSH-approval for dust, mist, and fumes should provide adequate protection when properly fitted and worn by a clean-shaven person.

Disks and Blades

Disks and blades are available in three basic types:

- abrasive disks
- diamond-tipped blades
- carbide-tipped blades.

Use only the disks and blades compatible with your saw and rated for its maximum rpm. Blades or disks may fly apart if their rpm is not matched to saw rpm. If you have any doubts, consult the operating manual or a reputable supplier.

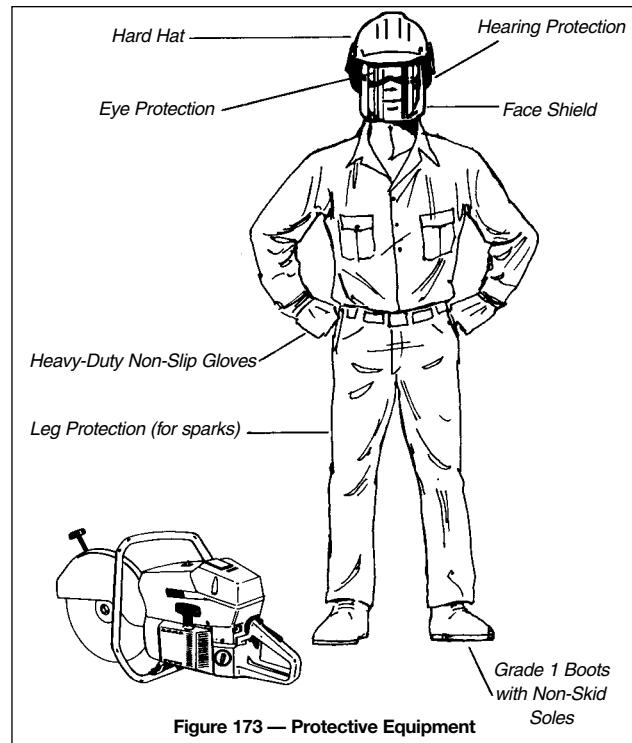

Figure 173 — Protective Equipment

Abrasive Disks — Types and Uses

Type	Uses	Materials
Concrete	All-around use, most economical for cutting concrete and masonry. Water-cooling recommended to increase disk life and reduce dust.	Concrete, stone, masonry products, cast iron, aluminum, copper, brass, cables, hard rubber, plastics.
Metal	Primarily for steel, not suited for masonry products. Water-cooling is not recommended with metal abrasive disks.	Steel, steel alloys, other hard metals such as cast iron.

Diamond Disks and Blades

Diamond disks are normally used with water cooling. They are now available for dry cutting, which may be necessary to avoid staining some masonry products.

When dry-cutting with a diamond blade, let the blade cool for 10-15 seconds every 40-60 seconds. This can be done simply by pulling the saw out of the cut.

Types and Uses

Type	Uses	Materials
Diamond Abrasive Disk	Cuts faster than other abrasive disks and creates less dust. Water-cooling is absolutely necessary to prevent heat build-up that can make disk disintegrate.	Stone, all masonry and concrete products. Not recommended for metals.
Dry-Cut Diamond Blade	Fast cuts, lots of dust, very expensive. Let blade cool for 10-15 seconds every 40-60 seconds. Continuous cutting will damage the blade.	Stone, all masonry and concrete products. Not recommended for metals.

Carbide-Tipped Blades

These blades must be used with care. If a carbide-tipped blade encounters material harder than what it is designed to cut, the tips may fly off.

A carbide-tipped blade used with a quick-cut saw **must** be designed for that purpose. It must also be used only to cut the materials specified by the manufacturer.

Inspection/Installation

Inspect disks and blades before installing them.

- Make sure that contact surfaces are flat, run true on the arbor, and are free of foreign material.
- Check that flanges are the correct size and not warped or sprung (Figure 174).

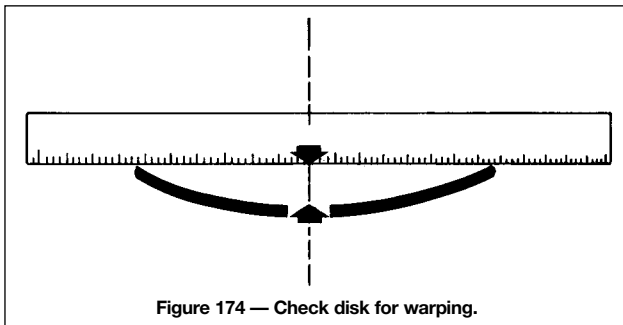

Figure 174 — Check disk for warping.

- Check the label to make sure that the disk or blade is approved for use on high-speed quick-cut saws and has a rated rpm suitable to the saw being used. A periodic service check may be necessary to ensure that the rpm still meets the manufacturer's requirement.
- Inspect the disk or blade for damage. Abrasive disks tapped lightly with a piece of wood should ring true. If the sound is dull or flat, the disk is damaged and should be discarded.
- Make sure that diamond or carbide tips are all in place. Do not use diamond or carbide-tipped blades or disks if any tips are missing.
- Do not drop abrasive disks. Discard any disk that has been dropped.
- Use the proper bushing on the arbor so that the disk runs true on the shaft without wobbling or vibrating.
- Discard badly worn disks that are uneven or "out of round."

Table Saws

Types

The table saw most often used in construction is the 10-inch belt-driven tilting arbor saw. The dimension refers to the diameter of the saw blade recommended by the manufacturer.

Although some saws are direct-drive (Figure 175), with the blade mounted right on the motor arbor, most are belt-driven (Figure 176).

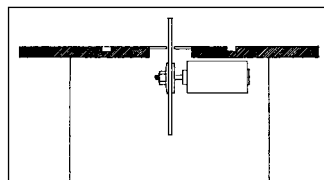

Figure 175 — Direct-Drive Table Saw

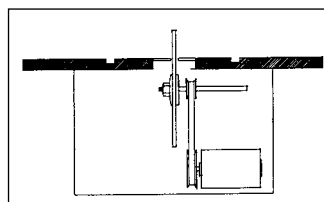

Figure 176 — Belt-Driven Table Saw

Both types are equipped with a fixed table top and an arbor that can be raised, lowered, or tilted to one side for cutting at different depths and angles.

Basket Guards

Basket guards may be fastened to the splitter or hinged to either side of the saw on an L-shaped or S-shaped arm (Figure 177).

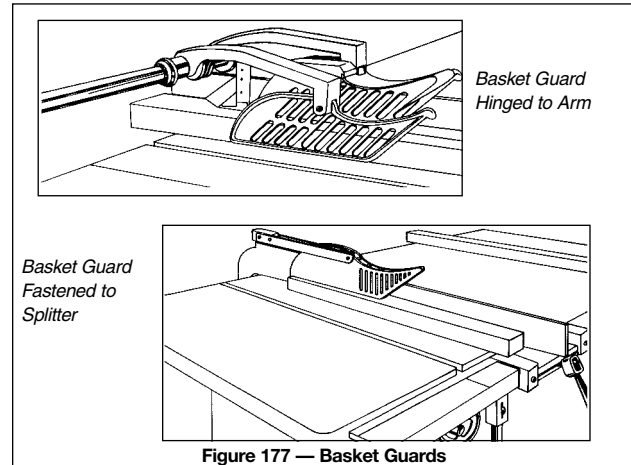

Figure 177 — Basket Guards

Basket guards can protect the operator from sawdust, splinters, and accidental contact with the blade. Keep the basket guard in place for normal operations such as straight and bevel ripping and mitre cutting. When the guard is removed to permit cutting of tenons, finger joints, rabbets, and similar work, use accessories such as feather boards, holding jigs, push sticks, and saw covers.

Figure 178 shows a split basket guard with a see-through cover. One side can be moved sideways for a blade tilted to 45 degrees. One side can be lifted up while the other remains as a protective cover.

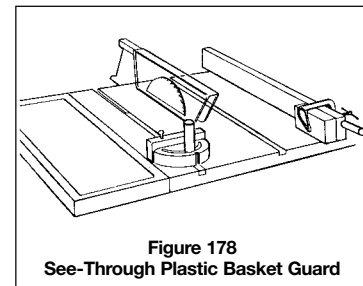

Figure 178
See-Through Plastic Basket Guard

Sheet metal baskets fastened to the splitter are less effective because the operator cannot see the saw blade.

Kickback

Kickback occurs when stock binds against the saw blade. The blade can fire the wood back at the operator with tremendous force, causing major injuries to abdomen, legs, and hands.

- Never stand directly behind the blade when cutting. Stand to one side. See that other workers stand clear as well.
- Make sure the rip fence is aligned for slightly more clearance behind the blade than in front. This will help prevent binding.
- Use a sharp blade with teeth properly set for the wood being cut. A dull or badly gummed blade will cause friction, overheating, and binding.
- Install a splitter to keep the kerf (cut) open behind the blade. Also effective are anti-kickback fingers attached to the splitter.

Splitters

Splitters prevent the kerf from closing directly behind the blade. Ideally, they should be slightly thinner than the saw blade and manufactured from high tensile steel.

Splitters are not always needed with carbide-tipped saw blades, whose relatively wide kerf may provide the desirable clearance. A wide kerf alone, however, is often not enough to keep some boards from closing behind the cut and binding against the blade.

In general, it is impossible to predict how a board will behave during ripping. It may remain straight, presenting no problems. On the other hand, the release of internal stresses may make the two ripped portions behind the blade either close up or spread apart.

Figure 179 shows a disappearing splitter with anti-kickback fingers. It can be pushed down when in the way of a workpiece and pulled up when necessary after the machine has been shut off.

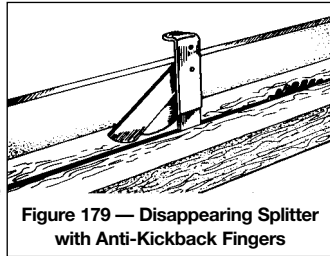

Figure 179 — Disappearing Splitter with Anti-Kickback Fingers

Roller Stand

Operators risk injury trying to maintain control over long pieces of stock singlehandedly, especially if the stock begins to bind on the blade and kick back.

A roller stand (Figure 180) provides the needed support. Adjust it to a height slightly lower than the saw table to allow for sagging of the material. Be sure to set up the stand so the roller axis is at 90 degrees to the blade. Otherwise, the roller could pull the stock off to one side and cause binding.

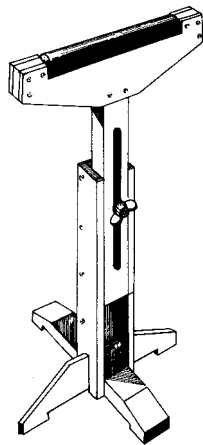

Figure 180 — Roller Stand

Whatever the design, a support stand should be standard equipment in every carpentry and millwork shop. It can be used as an extension to a workbench, jointer, or bandsaw and is especially important with the table saw.

Extensions

Made of wood or metal, table top extensions installed behind and to both sides of the machine can make the cutting of large sheets of plywood and long stock safer and more efficient.

In most cases a space must be provided between extension and saw top for adjusting the basket guard and allowing scrap to fall clear.

Blades

Table saw blades are basically similar to those for circular saws.

The teeth on carbide-tipped, hollow-ground, and taper blades do not need setting (Figure 181).

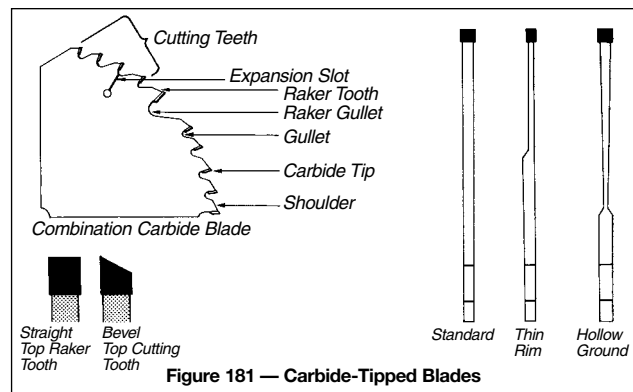

Figure 181 — Carbide-Tipped Blades

Blade Adjustment

Proper adjustment of cutting depth holds blade friction to a minimum, removes sawdust from the cut, and results in cool cutting.

Sharp blades with properly set teeth will keep the work from binding and the blade from overheating and kicking back.

The blade should project the depth of one full tooth above the material to be cut. When using carbide-tipped blades or mitre blades let only half a tooth project above the material.

Blade Speed

The right cutting speed is important. The blade should turn at the correct rpm to yield the recommended cutting speed.

When not in motion, saw blades, especially large blades, are usually not perfectly flat because of internal tensions. At the right operating speeds, however, the blades straighten out as a result of centrifugal force and cut smoothly at full capacity.

Blades running too fast or too slow tend to start wobbling either before or during a cut. If cutting continues, the blade will overheat and may cause kickback, damage the equipment, and injure the operator.

Rip Fence

The rip fence is used mainly to guide the stock and maintain correct width of cut. The fence on small saws is usually clamped down at both the front and back of the table by pushing down a lever or turning a knob. Adjust the fence slightly wider at the back to let the wood spread out behind the cut and reduce the risk of kickback.

Many carpenters add a piece of hardwood to the rip fence in order to rip thin pieces of wood and make dadoes and rabbets. The auxiliary fence can be set close to the cutters without the risk of contact between the blade and the steel fence.

Pushsticks

Narrow pieces can be cut safely and efficiently with the help of pushsticks (Figure 182), which should be painted or otherwise marked to prevent loss.

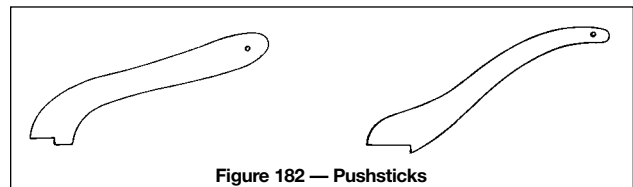

Figure 182 — Pushsticks

To rip narrow, short pieces, a push block is the right choice (Figure 183). The shoe holds the material down on the table while the heel moves the stock forward and keeps it from kicking back.

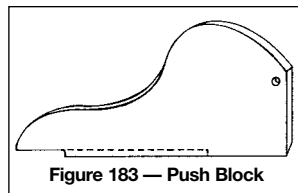

Figure 183 — Push Block

Different designs of pushsticks are required for cutting different kinds of stock.

The heel of the pushstick should be deep enough to prevent it from slipping and strong enough to feed the stock through the saw.

Feather Boards

You can also use one or two feather boards (Figure 184) to rip narrow stock safely. A feather board clamped immediately in front of the saw blade will provide side pressure to the stock without causing binding and kickback. Use a push block to feed stock all the way through.

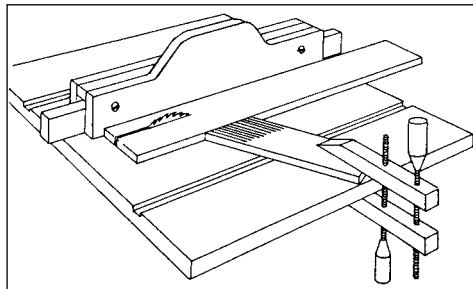

Clamp feather board in front of saw blade.

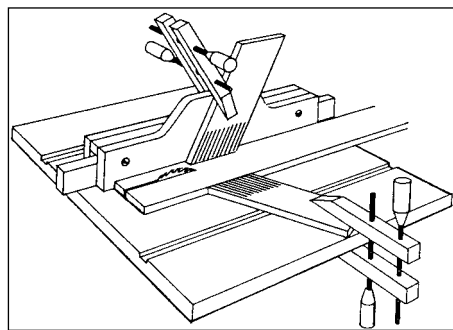

Clamp second feather board to auxiliary rip fence.

Figure 184 — Feather Boards

Operation

- Follow **Basic Saw Safety** (page 221).
- Keep the floor around the saw clear of scrap and sawdust to prevent slipping and tripping.
- Always stop the machine before making adjustments. Before making major adjustments, always disconnect the main power supply.
- Select a sharp blade suitable for the job.
- Use the safety devices such as pushsticks and feather boards recommended in this chapter.
- Make sure nobody stands in line with a revolving blade.
- Don't let anyone or anything distract you when you are operating the saw.
- Whenever possible, keep your fingers folded in a fist rather than extended as you feed work into the saw.
- Never reach around, over, or behind a running blade to control the stock.
- Follow the manufacturer's recommendations in matching the motor size to the saw. Underpowered saws can be unsafe.

- Table saws should be properly grounded. Check the power supply for ground and always use a ground fault circuit interrupter. This is mandatory for saws used outdoors or in wet locations.
- Table saws should be equipped with an on-off switch so power can be shut off quickly in an emergency.
- A magnetic starter switch is preferable to a mechanical toggle because it prevents the saw from starting up again unexpectedly after an interruption in power.
- When purchasing a new table saw, try to get one equipped with an electric brake. The brake stops blade rotation within seconds of the operator turning off the saw. The reduced risk of injury is worth the extra cost.
- Extension cords should be of sufficient wire gauge for the voltage and amperage required by the saw and for the length of the run.

Radial Arm Saws

The motor and blade of the radial arm saw are suspended above the table (Figure 185). Because the motor and blade assembly can be locked in different positions and can travel during the cut, the operator must pay special attention to keeping fingers and hands clear.

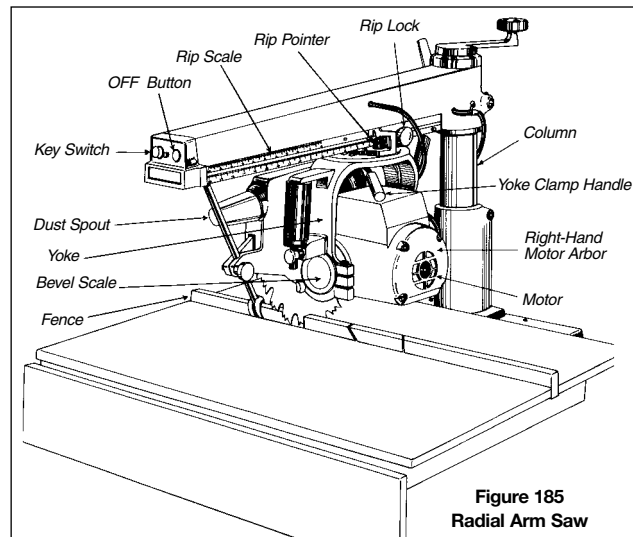

Figure 185
Radial Arm Saw

Injuries involving radial arm saws tend to be serious. By using appropriate guards and procedures, however, operators can safely use the saw for crosscuts, mitre cuts, ripping, and dadoes.

Set-Up

- The saw must be adequately powered for the work, especially for cutting thick hardwood.
- The saw should be installed in a well-lit area out of the way of traffic, with enough space to store and handle long lengths of wood. Locating the machine with its back to a wall or partition can help to keep flying pieces from hitting anyone.
- Where possible, mark the floor with yellow warning lines to keep other personnel back from the saw.
- Make sure all safety guards and devices are in place.
- Choose the right blade for the job. A sharp tungsten carbide combination blade is good for both crosscutting and ripping without frequent

resharpening. For information on blade types and uses, refer to earlier sections of this chapter.

General Procedures

- Follow **Basic Saw Safety** (page 221).
- If you don't have someone to help with long stock, use a roller stand or extension table to support the work.
- Always return the motor head to the column stop.
- When crosscutting or mitring, keep hands at least six inches away from the blade. **Do not adjust length of cut until the motor is back at column.**
- Slope the table top back slightly to keep the blade at the column, thereby preventing contact with stock being placed in position.
- Do not allow the blade to cut too quickly when crosscutting or mitring.
- Avoid drawing the blade completely out of the cut. The cut piece, whether large or small, often moves. When the saw is rolled back towards the column, the teeth can grab the piece and shoot it in any direction.
- Do not cut by pushing the saw away from you into the stock. The material can lift up and fly over the fence.

Ripping and Crosscutting

- For regular ripping, turn the motor away from the column to the in-rip position. Feed stock into the saw from the right side.
- To cut wide stock, change the saw to the out-rip position. Feed stock into the saw from the left side. Operators accustomed to in-ripping may find this set-up awkward. Remember – the blade must turn **up and toward** the person feeding the stock.
- Do not force the cut. Allow the blade through the wood at its own pace.
- **To avoid kickback, take the following precautions.**
 - Maintain proper alignment of blade with fence.
 - Adjust anti-kickback device (Figure 186) to 1/8 inch below the surface of stock being fed.

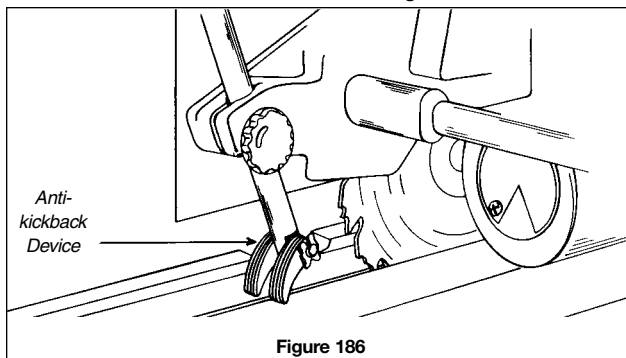

Figure 186

- Use a sharp blade, free of gum deposits and with teeth properly set.
- When binding occurs, stop saw and open kerf with a wedge.
- After completing cut, remove stock from rotating blade to prevent overheating and possible kickback.
- Always push stock all the way through past the blade.
- Do not leave machine with motor running.
- Use a push stick when ripping narrow pieces. Have suitably sized and shaped pushsticks for other jobs as well.

See information on pushsticks and feather boards under Table Saws, earlier in this chapter.

Jigs

The control provided by a well-made jig is essential for making irregular cuts safely and accurately.

Keep commonly used jigs (Figure 187) on hand. Jigs such as those for making stair and doorframe wedges and tapers are designed to carry stock past the blade with the saw locked in the rip position.

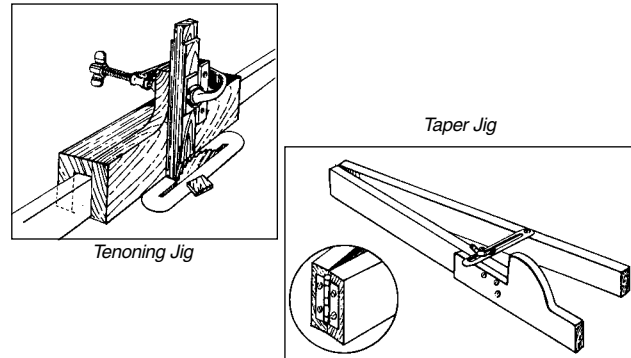

Figure 187 — Jigs

When you're drawing the saw into the stock, clamp or nail jigs to the table to prevent slipping.

Re-Sawing with Blade Horizontal

The rip fence on the radial arm saw is too low for supporting material to be re-sawn on edge. Therefore the material must be laid flat on the table and the motor must be turned so the blade is parallel to the table. The closeness of the arbor requires an auxiliary table top and fence to re-saw thin stock.

Because the kickback fence can't be used and controlling stock is sometimes difficult, re-sawing on the radial arm saw can be hazardous.

If no other equipment is available, rip the stock halfway through, then turn it around and complete the cut.

On the second cut, be sure to push the two halves well past the blade once they have been cut apart. Pushsticks and featherboards clamped to the table can reduce hazards.

Dadoes

A dado head is an essential tool for cutting grooves, rabbets, and dadoes. A groove is cut with the grain; a dado is cut across the grain; and a rabbet is a shoulder cut along the edge of a board.

The most common dado head consists of two outside cutters and several inside chippers between the outside cutters (Figure 188).

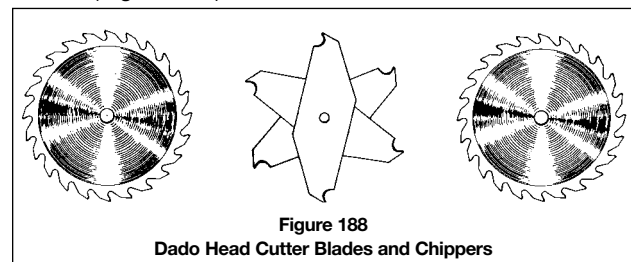

Figure 188

Dado Head Cutter Blades and Chippers

Another type is sometimes called a quick-set dado, consisting of four tapered washers and a blade. By

rotating the locking washers, the blade will oscillate and cut a groove to the desired width.

Because of their small size, dado heads do not run at the peripheral feed speed on a big radial arm saw. As a result, the blade feeds itself too fast, either stopping the motor or lifting the work and throwing it back. To prevent this, **make several light passes**, lowering the dado head 1/8 to 1/4 inch each time.

Dado heads require guards for safety. Always make sure guards are in place before starting work.

Proper rotation of the teeth is **up and toward** you.

Other Accessories

Rotary accessories of various types are advertised as turning the radial arm saw into a multifunction machine. Operators should remember that the saw has its limitations. Possible problems include the following.

- Shaper heads run too slow for safe and smooth work.
- Grinding stones may run too fast or slow and are not recommended.
- Sanding drums tend to run too fast and may burn the wood.

4 POWER TOOLS — AIR

Many different types of tools are powered by compressed air. They are fast, powerful, and ideal for repetitive tasks such as the nailing of large areas of roof decking or chipping and breaking concrete. A compressor, powered by a combustion or electric motor, supplies the air for the tools.

Air-powered tools include

- jack hammers
- chipping hammers
- drills
- grinders
- sanders
- staplers
- framing nailers
- wrenches
- brad nailers
- winches
- air nozzles
- saws
- buffers
- impact tools
- sprayers.
- Run combustion engines outside or in a well-ventilated area to prevent the build-up of carbon monoxide gas. Always keep a fire extinguisher near flammable liquids.
- When moving compressors to another location, ask for help or use mechanical devices to prevent back injuries.
- Occasionally workers suffer eye injuries when compressed air is used to blow out formwork. Wear safety goggles and respiratory protection.
- Always secure hose connections with wire or safety clips to prevent the hose from whipping except when

automatic cut-off couplers are used.

- Make sure hoses are clear of traffic and pose no tripping hazards.
- Replace worn-out absorption pads and springs. Too much vibration of the tool can damage nerves in fingers, hands, and other body parts. This is called “white finger disease” or Raynaud’s Syndrome.
- Some tools have a high decibel rating – for instance, jack hammers and impact drills. To prevent hearing loss, always wear hearing protection.
- Never tamper with safety devices.
- Keep hands away from discharge area – on nailers in particular.
- Match the speed rating of saw blades, grinding wheels, cut-off wheels, etc. to tool speed. Too fast or too slow a rotation can damage the wheels, release fragments, and injure workers.

• Never use air to blow dust or dirt out of work clothes. Compressed air can enter the skin and bloodstream with deadly results.

- Turn off the pressure to hoses when the system is not in use.
- Turn off the air pressure when changing pneumatic tools or attachments.
- Never “kink” a hose to stop air flow.

Most air-powered tools need very little maintenance. At the end of the shift, put a teaspoon of oil in the air inlet and run the tool for a second or two to protect against rust.

Dust, moist air, and corrosive fumes can damage the equipment. An inline regulator filter and lubricator will extend tool life.

Before start-up, check the couplings and fittings, blow out the hose to remove moisture and dirt, and clean the nipple before connecting the tool. Set the air pressure according to the manufacturer’s specifications and open gradually.

Compressed air can be dangerous. Hazards include

Air embolism	This is the most serious hazard, since it can lead to death. If compressed air from a hose or nozzle enters even a tiny cut on the skin, it can form a bubble in the bloodstream – with possibly fatal results.
Physical damage	Compressed air directed at the body can easily cause injuries – including damage to eyes and ear drums.
Flying particles	Compressed air at only 40 pounds per square inch can accelerate debris to well over 70 miles per hour when it is used to blow off dust, metal shavings, or wood chips. These particles then carry enough force to penetrate the skin.

WARNING: Make sure that air pressure is set at a suitable level for the tool or equipment being used. Before changing or adjusting pneumatic tools, turn off air pressure.